

L5.20:
238

Home Play and Play Equipment for the Preschool Child



~~27~~
~~458~~
~~#238~~
CHILDREN'S BUREAU PUBLICATION NO. 238

United States Department of Labor

UNITED STATES DEPARTMENT OF LABOR

FRANCES PERKINS, Secretary

CHILDREN'S BUREAU . . KATHARINE F. LENROOT, Chief



HOME PLAY AND PLAY EQUIPMENT
FOR THE
PRESCHOOL CHILD



Bureau Publication No. 238

United States
Government Printing Office
Washington : 1937

For sale by the Superintendent of Documents, Washington, D. C. - - - - - Price 10 cents

CONTENTS

| | Page |
|---|------|
| Play a way of learning | 1 |
| Playing alone | 2 |
| Playing with other children | 3 |
| Parties and Christmas | 3 |
| Imitative play | 4 |
| Pretending | 4 |
| Training the senses | 5 |
| Play equipment | 6 |
| Toys | 6 |
| Books and pictures | 7 |
| Outdoor play equipment | 8 |
| Suggestions for further reading | 20 |

Home Play and Play Equipment for the Preschool Child¹

PLAY A WAY OF LEARNING

Play is the child's way of learning, of experimenting, of trying himself out, of finding out about everything in the world around him. It is full of pleasure for him, for it is full of new experiences and new combinations of past ones. Play is, at the same time, a serious thing to him and should be planned for seriously by his parents.

Every mother can learn a great deal about play if she will watch her child and not interfere with him. By the time he is a year old he bangs his toys to make a noise and piles blocks one on the other. He fills his pails with sand and empties them again; he points out figures or colors in his picture books, trying to repeat the word he heard when someone else pointed them out.

Gradually, as the child grows older, he becomes more skillful in his movements and can pile his blocks higher and even tries to catch a ball and later to string large beads. Things that he could not do a few months before are becoming easy. He wants toys with which he can do something. He learns to walk, and with this new accomplishment he starts the pulling and pushing kinds of play. He drags along the floor a toy dog or a box tied to a string, and shoves a chair across the room. Perhaps you have shown him how to throw a ball, and he suddenly begins to throw everything he can reach. Then, perhaps, he finds a crayon and scribbles with it on paper, on the walls, on the floor.

At 2 or 3 years he begins to play with other children of his age. If he has older brothers and sisters, they may try to make him share their games, though at first he will not know what they are driving at. To play his part, to wait his turn, to follow the rules of the game, to pay a penalty if he plays out of turn are ideas that are as yet over his head. After a while he will have grasped them and with them some of the fundamental lessons of happy living.

When a mother has thus stopped and looked at her child's play, she realizes that play is his way of learning. Through it he becomes skillful in the use of his muscles. The little child who can put the last block on top of his tall tower without upsetting it may well dance up and down with pleasure at his accomplishment. He has learned something quite as important for his age

¹ The material in the first part of this bulletin is reprinted from *The Child From One to Six*, Children's Bureau Publication No. 30. Washington, 1935.

as how to add 2 and 2 will be later. Encourage this training of senses and muscles. Give the child toys that call upon him to use new combinations of movements. Playing with a bean bag or a game of ring-toss teaches him to throw accurately, stringing beads teaches another kind of skill, drawing on a blackboard another. The big muscles of the back and abdomen are made strong by climbing, swinging, walking on all fours, and turning somersaults.

Do not try to teach a little child to use the small muscles first. Stringing large beads, drawing on large sheets of paper, tearing and cutting out large figures are much better for the young child from 2 to 5 than trying to do anything fine with the hands like sewing cards and weaving.

Perhaps the most important lesson learned through play is that of coordination, or the working together of muscles and senses. When you watch a 6-year-old girl jumping rope to the sound of her own singing, or that of her playmates, you perhaps do not realize that the working together of eye, ear, and muscles in perfect rhythm is the result of the lessons learned through play during the preschool years. Childhood is the right time to learn this type of skill; the child who has played with vigor and freedom attains it without conscious effort.

A child needs to walk and to run, to climb, to swing, to ride, to pull, to push, to dig, to throw. He needs to have his interests always widening. Although quiet play is important, especially for the little child, at least a part of every child's play should be free and active.

It is best to have the room in which he plays indoors so arranged that he can play freely all over it (or in a fenced-off portion) and handle and touch everything within his reach. A playhouse or a porch that is fenced and screened but open to the sun is useful.

PLAYING ALONE

It is worth while for every mother to teach her child to enjoy being alone. The mother who hurries to pick up the baby as soon as she hears him cooing or talking to himself is making trouble for herself. Any child who is used to being left alone will play very happily by himself and amuse himself with a tin pan and a spoon, clothespins, blocks of wood, or other toys with which he can make or do something.

By playing alone without adult interference or help the child learns to make his own choices, his own decisions; he learns to concentrate his attention on what he is doing; he learns some of his first lessons in independence. Do not interfere with the child's play. If he seems to you to be doing something awkwardly, do not try to do it for him. Let him learn by doing it himself. Even if the result is not up to your standards, it may be very good for one of his experience.

A little child will do the same thing over and over without tiring. He needs much practice if he is going to learn to do things well. Give him ample opportunity to practice climbing, balancing, pushing, talking, singing, sweeping, dusting, shoveling, hammering. Do not interfere in

these activities. Let him learn that success comes only through trying and failing and trying again.

A play pen or a fenced-in part of the yard is a great help to the busy mother. In the pen the child who has not yet learned to climb is safe; and if it is built with a floor, which is covered with a blanket or quilt (except in hot weather), he will escape the cold and the drafts that make play on the floor uncomfortable. The pen should be large enough to allow him considerable freedom of movement, and he should have things to play with so that he will not stand hanging to the side of the pen too long.

PLAYING WITH OTHER CHILDREN

A little child also needs other children to play with. Adults or older children cannot take the place of companions of the child's own age. A little child needs to play and develop with other children who are in the same stage of learning as himself, who are his equals, as well as with those who are a little older or a little younger. The parents of an only child especially must bear this in mind. Through group play a little child learns by following the example of others, by having to consider what others want, by finding out that he can set an example which others will follow.

He learns many valuable lessons in adjusting himself to the demands and ideals of his group as he will later have to adjust himself to the demands and ideals of his community. Self-reliance, initiative, and leadership develop through group play.

Parents should know who are the companions of their child; he may be learning from them to play fair or to cheat. Be careful about letting a little child play out of your sight with children of whom you know nothing. Listen to their talk as they play, and see that no one teaches your child "not to tell your mother" or to "hide it, your father might see." There are plenty of playmates who will help you teach your child fair play, honesty, and courage. It is well for children to learn early that certain rules of the game must be observed, that no one can always win or always have his way, that a good sport can lose without sulking, and that crying is unpopular.

When children are playing together, interfere as little as possible. It is usually better to let them settle their own disputes. Do not encourage tale-bearing; but if you are asked to settle a disagreement, hear both sides and help the children to make their own decision fairly. At times interference is necessary; no one should permit cruelty or dishonesty among children.

PARTIES AND CHRISTMAS

Parties for children under 6 years of age should be very simple and occur very seldom. Above all they should be small, not more than three or four children, especially for the child who is not accustomed to playing in a group. Parties should not interfere with the regular nap and meal times. Unusual foods should not be served, nor should any food be served at unusual times. Foods that would usually be served for dinner or supper

may be served in special dishes or in a special manner, such as fancy shapes for cookies or oranges, or sandwiches instead of bread. The child for whom the party is being given may be allowed to choose which of the usual dishes he would like to have.

Simple table decorations may add a little extra color. The children should not be dressed up in fancy clothes that may be spoiled by play. The getting together of a few children for play is in itself sufficiently exciting and unusual to the average little child to warrant the name of a party. Simple games without undue excitement, played outdoors in a group, followed by a simple supper at the usual time, make the best kind of party for little children.

Do not overdo the Christmas festivities for children. A tree hung with apples and a few shining ornaments and festooned with strings of cranberries and popcorn and colored papers gives just as much pleasure as one elaborately trimmed. Simple toys are often those most loved by children. It is often the parents who cannot afford to spend much money at Christmas who succeed in making it the happiest time. Christmas can be made a truly happy time for the children by avoiding confusion, fatigue, too many things at once, too much excitement, upsetting of the daily routine, and unusual food. One mother lessened the confusion by having the little children get their presents at a different time from the adults and by putting away all but a few toys after a short time. She also insisted on an outdoor playtime and a long midday rest for all. The children had their dinner alone, and she made it a simple meal of the things they liked; she knew that digestions are upset very easily by excitement, and she gave them no rich and unusual food at dinner and no candy between meals.

Do not take a little child to public gatherings, such as fairs or circuses, or into crowded stores. These are always overexciting and overfatiguing and offer great risk of infection. Unless you suggest to the child that he is missing something by not going to such places, he will feel no disappointment. A child should not be expected to sit through movies or other entertainments suitable only for grown-ups.

IMITATIVE PLAY

Much of a child's play, whether he is alone or in a group, is imitation of what he has seen and heard about him. He learns to do the ordinary things of life by practicing them in his play. A child will act out the events of the household, going over and over what he sees and hears, and he sees and hears just about everything that goes on.

PRETENDING

The little child enjoys his toys because of what he can do with them; as he grows older he enjoys them also because of what he can pretend they are. He will often play in an elaborate world of make-believe, perhaps with dolls or boxes, blocks, flowers, stones, or bits of wood and china.

All these things take on an importance to him that the grown-up outsider sometimes finds it hard to see. The flowers may be people, and the blocks, boats or engines. In his imagination he may turn his playroom into a wood full of wild animals or a lake with each chair a boat. He is happy so long as he is allowed to play in this way, but he may be made most unhappy by the misunderstanding adult who destroys his fairy castles. Play of this kind is used most often by a child who plays alone; less often children playing together will build up a make-believe world.

It is well for the parents to respect and enter into the spirit of such play. "Let's pretend" is a part of every life, and the imagination of the child should be helped to grow in a healthy direction; however, this make-believe life should not occupy a child's whole time. Play with real toys and real children should be a larger part of his life.

Dressing up to play parts, especially with costumes, is usually enjoyed by children playing together. This kind of play cultivates the imagination and at the same time encourages a social spirit.

TRAINING THE SENSES

Teach the child to enjoy form and color, to draw, however crudely, and to make patterns out of colored blocks. Help him to develop the sense of touch shown by the child who is letting sand run through his fingers, shaping a mud pie, or tenderly smoothing a piece of satin or velvet dropped from his mother's sewing box. Even the very young child may get great pleasure out of beautiful sounds and shapes and colors. Musical interest is keenly developed in some young children, and a piano, a phonograph, or a radio is a great source of pleasure and instruction.

Rhythmic movements to music are a great pleasure to most children—singing, marching, keeping time to music with hands or feet or bodies. Thus they learn to appreciate and respond to rhythm, to recognize and reproduce musical sounds. Such activities help to develop love of music as well as skillful use of the body. Every child who plays the singing, dancing games of childhood is getting his ear as well as his muscles trained. Ball-bouncing games and hopping games also are of the rhythmic type.

PLAY EQUIPMENT

TOYS

There are two kinds of toys—those that the child can do something with and those that he can only watch. Children enjoy for years their sand boxes, blocks, balls, tools, wagons, dolls, dolls' furniture, and the many other toys out of which they can make something or with which they can do something new; but they soon tire of the toys that they only watch—the ordinary mechanical toys. Certain mechanical toys are of interest to a child, such as a phonograph that can be handled easily by a child of 3 and an automobile that he can wind up and steer. Many a child takes more pleasure in a dozen clothespins and a few pieces of cloth to wrap around them than in an elaborate ready-made doll whose clothes will not come off. The little child is interested in making, in building, in doing—not in looking on. Encourage him in this, for if he does not develop this interest early in life, he may grow into the kind of person who is always a looker-on and not a doer.

Blocks should be part of the equipment of every playroom. Plain blocks, colored blocks, large ones and small—all blocks are worth-while toys. They are used in many ways—to build houses, barns, fences, or roads. They become trucks and railroad trains. The colored ones that offer a chance to experiment with patterns, shapes, and matching of colors delight children. Wooden blocks in the shape of a train of cars, which can be taken apart or hitched together easily, are good. Blocks may be made at home by cutting a piece of lumber known as a two-by-four into 2-inch lengths and sandpapering the pieces until they are smooth. So as not to be too heavy, large blocks may be made like boxes with covers nailed on. Mill blocks or pieces of scrap lumber, which are sold at a few cents a hundred at the lumber yard, are excellent blocks for small children. They come in different sizes and shapes. Unless very smooth mill blocks are chosen, the rough edges should be planed or sandpapered.

Balls are always satisfactory toys for young children. Very large balls to be rolled on the floor, smaller balls to throw, rubber balls to bounce, colored balls, balloons on a string, are all good.

Large sheets of paper should be provided for drawing. The paper may be unprinted newspaper (newsprint), purchased at the newspaper office, or light-colored wrapping paper, or samples of wallpaper. Crayons; a blackboard and colored chalk; clay or moist sand for modeling; blunt scissors and large pictures to cut out; bright-colored pieces of paper in different shapes that can be used for folding, cutting, or pasting; a peg board with large colored pegs and holes; large colored beads to string—all are toys in which the 3- to 5-year-old child will take much interest if he is allowed to use them himself

Toys that can be pulled by a string, such as a horse and wagon, or a truck, or a train of cars, are of special interest to the 2- to 4-year-old child if they are large enough to be loaded with blocks or sand and unloaded again. Electric trains are not suitable for children under school age. Egg boxes or other small, substantial boxes made of wood and fitted with ball-bearing casters make good wagons to haul blocks or toys in or for the small child to ride in. They can be used outdoors or indoors.

Dolls are an important part of playroom equipment for young children. Dolls made of heavy rubber are durable and washable. They are sold in many different sizes. Soft rag dolls or dolls made of cloth and painted so that they will wash are also good. Soft woolly animals and other toy animals; housekeeping toys of all sorts—small tables, chairs, dolls' beds, bureaus, carriages, dishes, kitchen stoves and pots—gardening and carpentry toys that are really useful and durable are needed.

Pieces of cloth or yarn, empty spools and boxes, wrapping paper and bags, colored cord, old clothing to dress up in, and discarded magazines are all valuable material for children to play with. Such kitchen utensils as egg beaters and pans that fit into one another are often absorbing toys to a young child. (Kitchen utensils that are sharp or in any other way dangerous should not be given to children.) Empty cans of different sizes may be made into a set of nested cans if the edges of the cans are made smooth.

Shelves of the right height for the little child are better than boxes for toys, for the child can keep the toys in better order on shelves. Toys that are kept in a box are more apt to be broken.

Avoid toys that are easily broken. Through them the child learns careless and extravagant ways. Toys should encourage constructive, not destructive, habits.

BOOKS AND PICTURES

The best books for the very little child are picture books made of cloth, for he can handle them without tearing the pages. Large, gaily colored pictures are his chief delight. Pictures of things that he knows about are of more interest to him than pictures of things he has never seen. Washable window shades cut into pages and sewed together make excellent scrap-books.

Children very early enjoy rhymes like the favorite, Mother Goose. The first stories children like to hear are simple ones with much rhythm and repetition. "This little pig went to market", "The house that Jack built", "Three little kittens" delight children. Probably they care less for the story than for the sounds. Interest in the story itself comes later, but the pleasure in sound and rhythm remains. Most children enjoy having simple stories read or told to them. They like to hear the same story told over and over again or to look at the same picture again and again. The parents may weary of a story long before the child is satisfied.

Choose pleasant, happy stories, whether you tell them or read them to the children. Do not give children pictures or books that may fill them with fears. Do not buy a book merely because it is cheap or has a pretty cover. Find out first whether it is the kind of book that the child will enjoy.

Pictures, preferably colored ones, of familiar animals or groups of children playing, or pictures illustrating nursery rhymes or stories, may be placed on the wall where the children can see them easily, not too high.

OUTDOOR PLAY EQUIPMENT

Some simple home-made play apparatus is needed in every back yard where little children play. A few smooth boards of different widths, lengths, and thicknesses, not too heavy for a little child to carry, can be used for building and climbing. Large blocks made like hollow wooden boxes are useful for pushing and climbing. Wooden packing boxes of different sizes, from which the extra nails have been pulled out so that the children can safely climb into the boxes, are material for playing house or store or for other imaginative play. Boxes made of veneer may be used, but they are not so strong as boxes made of solid wood. A piano box or any other large box with windows cut in the sides makes a good playhouse. The playhouse should be simple and easily changed about. Children like to make their own playhouses, and a packing box that is a house today may be a boat tomorrow.

A work table can be used outdoors as well as in the playroom. The work table for children 4 to 6 should be equipped with durable and efficient tools, such as a hammer with a short handle and a broad head; a small vise; a short, wide saw; and short galvanized nails with large, flat heads (roofing nails). There should be plenty of wood to work with—wood that is soft enough for the small child to saw easily and to drive nails into.

A back-yard pool for wading and sailing boats is popular with children, and a lawn shower is helpful in the summer. If the yard is large enough, each child should have space for a little garden of his own and tools for gardening.

Toys that encourage vigorous outdoor play are valuable. A tricycle, a wagon big enough to ride in, a wheelbarrow, and a sled give opportunity for much activity.

Not all back yards are large enough for climbing bars or slides, but such simple equipment as sand box, seesaw, packing boxes, swing, or horizontal bar can be used in small yards or even on a porch. The egg boxes fitted with casters described on page 7 are good playthings for a porch.

The equipment described in the following pages need not be built all at one time. The sand box, the play planks, and the packing boxes are a good combination to start with, and other pieces may be added later. Back-yard play equipment should be planned for the needs of the children when they grow older, as well as for the present. Such equipment as swings, rings, and

bars, if attached to frames that are large enough and well constructed, can be varied according to the interests of children of different ages.

The designs shown are for sturdy, long-time outdoor equipment. Fragile equipment is dangerous and in the long run expensive. These designs may be adapted, however, to the material and space at hand, but lumber or pipe that is used to make frames for swings or bars should not be below the minimum thickness or diameter given in the specifications.

Lumber that is well seasoned, comparatively straight-grained, and free from cracks or splits should be selected. All lumber used for playground apparatus should be surfaced on four sides and the corners planed. If lumber is difficult to use for frames, than wood and though it is usually more difficult to set pipe, 2 to 3 inches

to obtain, pipe may be used. Pipe is more durable, requires less care, more expensive and up. Galvanized iron in diameter, is best for play apparatus. Pipe and pipe fittings may be bought from hardware stores or plumbing firms. If second-hand lumber or pipe is used, it should be carefully selected and tested.

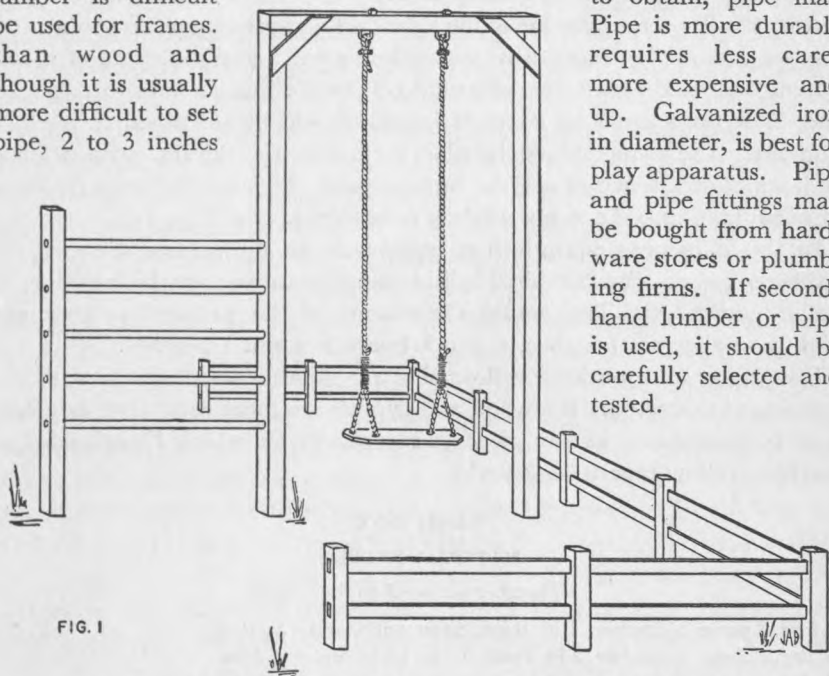

FIG. 1

Special fittings for swings and rings are sold by manufacturers of playground equipment and by dealers in hardware or in barn and hayloft equipment. The hooked bolt (fig. 19), galvanized thimble (fig. 20), and black enameled clamp (fig. 21) shown on page 16 cost only a few cents apiece. Although chain is more durable than rope, swings made of rope are strong enough for small children in the home playground. If chain is used, it should not be too heavy. With the fittings suggested, waterproof rope will make a safe and durable swing. The small additional expense of such special fittings will be justified by the longer life, easier upkeep, and greater safety of the apparatus.

Outdoor play apparatus must be constructed so that it is firm and secure. Uprights and cross beams must be set straight and level. Frames for swings

and bars need not be braced if they are set 3 feet deep in concrete. (For method of setting uprights in concrete, see pp. 13-14.)

Wooden apparatus should be given a coat of linseed oil and painted with waterproof paint as a protection from the weather. All parts of apparatus that are to be placed underground should be treated with a preservative to a point at least 6 inches above the ground. Friction points on metal should be greased frequently. Bolts should be used to fasten wooden parts together wherever it is possible; they fasten the parts more securely than nails and are less likely to split the wood or to work loose. Where wooden parts are bolted together, washers should be used to protect the wood, and the bolts should be tightened frequently. Bolt holes treated with a preservative will prolong the life of the joint. Playground apparatus should be inspected often, as ropes fray and bolts loosen. Sharp corners of swing boards and sand boxes should be cut off, as the illustrations on pages 16 and 11 show, and rough edges of boards should be smoothed to prevent splinters. The swing should be placed close to and parallel with a fence or a wall; or a fence should be built around the frame to keep children from running into the swing while it is in motion (fig. 1, p. 9).

In the following descriptions of equipment all dimensions specified for lumber represent the "nominal" dimensions according to which lumber is usually described. The actual dimensions of the surfaced lumber are slightly smaller; for instance, a 2-inch board is about $1\frac{5}{8}$ inches.

Douglas fir and southern yellow pine are suitable woods for most of the equipment described. Redwood and cypress are more expensive, but they may be substituted in any piece of equipment for which Douglas fir or southern yellow pine is suggested.

SAND BOX

MATERIAL NEEDED

(All lumber surfaced on four sides)

Sides: 2 pieces of lumber, 2 in. thick, 10 in. wide, and 6 ft. long.

Ends: 2 pieces of lumber, 2 in. thick, 10 in. wide, and 4 ft. long.

Shelves: 2 pieces of lumber, 2 in. thick, 8 in. wide, and 4 ft. 4 in. long.

Nails: 1 pound 16-penny common.

Sand: 1 wagonload (to fill the box to a depth of 8 in., approximately $\frac{1}{2}$ cu. yd. or 16 cu. ft. of sand will be required).

CONSTRUCTION

Nail the side boards to the ends. Center the boards for the shelves on the end boards and nail them firmly to both end and side boards, so that they are half inside and half outside the box and will not need to be braced (fig. 3). Cut off the sharp corners of the shelves. Brace the corners of the box with iron or wood. A wooden bottom in the sand box will keep the children from digging into the soil underneath and mixing it with the sand.

Any sound grade of softwood lumber can be used for the sand box. Among the low-priced woods are southern yellow pine, Douglas fir, ponderosa pine, and spruce. A low grade of white pine will also be suitable. The boards should be free from knot-holes and other defects through which the sand can sift readily. One-inch lumber may be used if stakes are driven into the ground at intervals to hold the boards in place.

No. 1 and No. 2 Common grades of lumber will be satisfactory for a sand box. Smooth boards should be selected, and the top edges of the boards, inside and outside, should be smoothed with a plane or a wood rasp and sandpaper.

The sand box should have a cover to protect the sand from stray cats and dogs. Canvas weighted at the corners with stones may be used, or wallboard nailed on two strips of wood may be laid over the sand box at night. Another type of cover is a light wooden frame covered with 1-inch galvanized-wire mesh, which permits the sun and air to reach the sand. To keep the sand dry in wet weather, however, a permanent cover, hinged to the box, is best. It may be made of waterproof canvas or other fabric stretched and nailed to a frame, or of wood, or of wallboard and wood. Both wood and wallboard should be painted with waterproof paint.

A sand box may keep a child playing happily in the sunshine if he has such simple things as spoons, muffin tins, pails, pans, a flour sifter, and a wagon. Unless the sand is

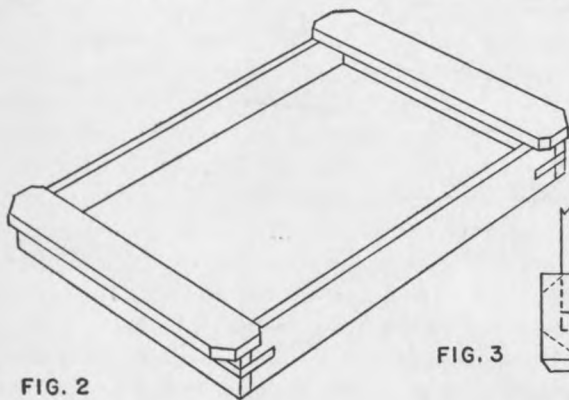

FIG. 2

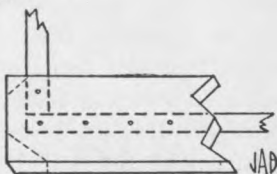

FIG. 3

moistened occasionally, it will get dusty. Small children need moist sand to mold their cakes and pies, and older children need it to make mountains and tunnels. Little stools or boxes, large enough for children to sit on but small enough for them to carry around, will help to keep children from sitting in the sand when it is too damp. The shelves on the ends of the sand box give them work tables or seats and help to keep the sand in the box.

This sand box is large enough for two or three children to play in. It should be placed where it will get the direct sun at some time during the day but where there is shade also. The sun helps to keep the sand clean. The shade adds to its comfort as a play spot. A tree, a shelter of vines or canvas, or a beach umbrella may be used for shade.

PLAY PLANK AND SAWHORSE

MATERIAL NEEDED FOR PLAY PLANK

(All lumber surfaced on four sides)

Plank: 1 piece of vertical-grained Douglas fir or southern yellow pine, 2 in. thick, 10 in. wide, and 12 ft. long. (Maple or birch, 1¼ in. thick, in Clear or Select grade, may be used.)

Cleats: 2 pieces of lumber, 2 in. thick, 4 in. wide, and 10 in. long.

CONSTRUCTION OF PLAY PLANK

Bolt a cleat to the bottom of the plank 6 inches from each end, as figure 4 shows (p. 12). This is to keep the plank from slipping when it is placed on boxes or on the sawhorse (figs. 6, 7, and 8, p. 12).

It is especially important that a plank that is to be used as a slide be free from splinters. Select a smooth, vertical-grained piece of lumber and give it the following treatment: A thorough sandpapering, a coat of linseed oil to protect it from the weather, a coat of white shellac or varnish, and a heavy coat of floor wax. The children should not be permitted to slide against the grain of the wood. A cleat at only one end of the plank that is to be used as a slide will help to prevent its being placed in the wrong position.

Planks that are not to be used as slides should be smoothed with a plane or a wood rasp, given a coat of linseed oil, and painted with waterproof paint.

The play plank may be placed across the sawhorse to make a seesaw (fig. 6). It may be used also on large blocks of wood or on the sawhorse as a slide board (fig. 7) or on two boxes as a walking board (fig. 8) for the smallest children to practice balancing.

There should be plenty of wooden boxes of different sizes to use with the play planks,

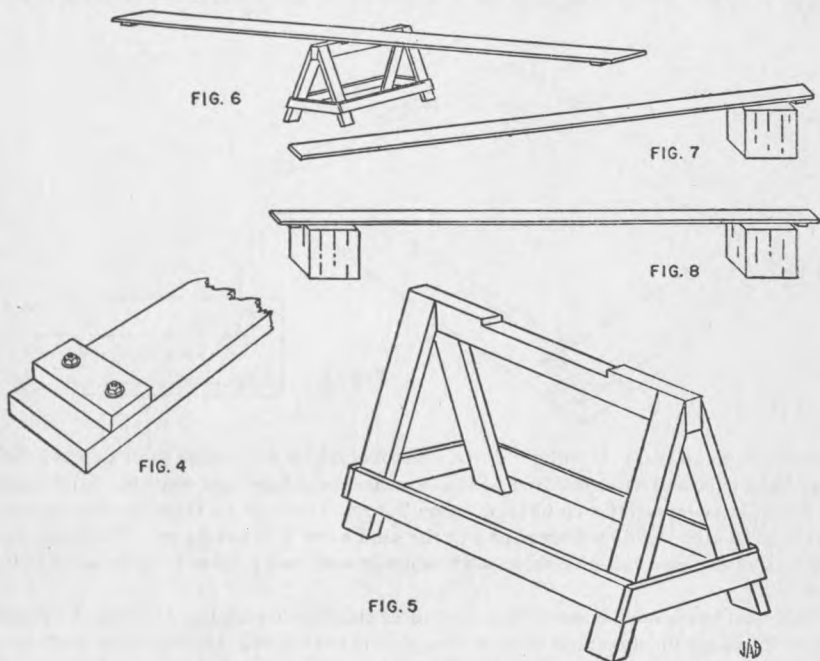

from closed boxes 5 inches by 5 inches by 8 inches to large packing boxes. The nails should be removed from the open end of the packing boxes.

MATERIAL NEEDED FOR SAWHORSE

(All lumber surfaced on four sides)

Top and legs: 1 piece of No. 1 Common grade Douglas fir or southern yellow pine, 2 in. thick, 4 in. wide, and 9 ft. long.

Braces: 1 piece of lumber, 1 in. thick, 4 in. wide, and 6½ ft. long.

Nails: 1 pound 16-penny common nails or carriage bolts.

CONSTRUCTION OF SAWHORSE

Saw the long piece of lumber as follows: top, 24 inches long, and 4 legs, each 20 inches long. At a distance of 6 inches from each end of the top, bolt two small blocks of wood or saw out a section ¼ inch deep, as in figure 5, to keep the play plank from slipping off the sawhorse. Saw the shorter piece of lumber into four pieces to be used as braces, as follows: two 24 inches, two 15 inches. Assemble the pieces and nail the sawhorse together as shown in figure 5.

SWING AND CLIMBING BARS

MATERIAL NEEDED FOR FRAME

(All lumber surfaced on four sides)

Uprights for swing: 2 pieces of No. 1 Common grade Douglas fir or southern yellow pine, 4 in. thick, 4 in. wide, and 14 ft. long.

Cross beam for swing: 1 piece of No. 1 Common grade Douglas fir or southern yellow pine, 4 in. thick, 4 in. wide, and 6 ft. long.

Upright for climbing bars: 1 piece of No. 1 Common grade Douglas fir or southern yellow pine, 4 in. thick, 4 in. wide, and 10 ft. long.

Braces: 4 pieces of No. 1 Common grade Douglas fir or southern yellow pine, 2 in. thick, 4 in. wide, and 8 ft. long (not required if uprights are set 3 ft. in concrete).

Nails: 1 pound 20-penny common nails and 1 pound 7-in. heavy nails or bolts.

(NOTE.—The frame may be made of 3-in. pipe of approximately the same lengths as the lumber.)

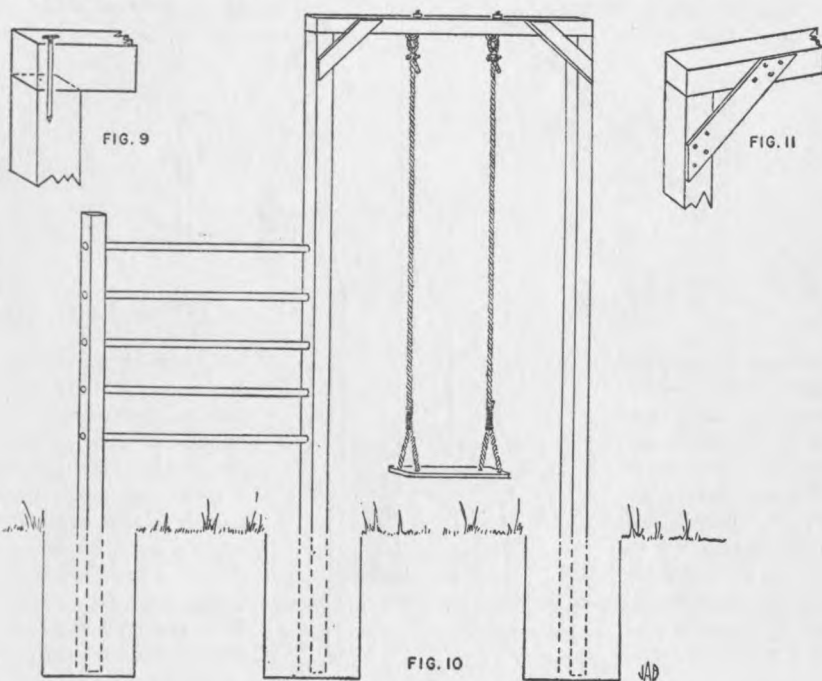

CONSTRUCTION OF FRAME

Unless specially treated lumber is bought for the uprights, the parts that are to be placed underground should be treated to a point 6 inches above the ground to prevent decay or damage from insects.

Fasten the cross beam to the tops of the uprights for the swing with heavy bolts or nails, as shown in figure 9. Square the beam and posts with a carpenter's level or a wide board that has been cut square. Brace the angles (joints) of the cross beam and uprights securely with wood or iron (fig. 11). Dig three post holes for the uprights 3 feet deep. Center the two post holes for the swing uprights 6 feet apart. The post hole for the other upright, to support the climbing bars, should be 4 feet from the upright for the swing. Make square forms for the holes (fig. 12, p. 14). Set the uprights on pieces of

wood so that they will be level. Rough, ready-made wooden boxes to fit the holes may be used as forms for the concrete. The uprights will not need permanent braces if they are set 3 feet deep in concrete. They must be braced temporarily, however, until the concrete is set (fig. 12).

Exact proportions for a concrete mixture cannot be specified, as the proportions depend upon the size and nature of the sand and gravel (aggregate) that is used. A proportion of water to cement that would give adequate strength in concrete foundations for playground equipment is 6 parts of water to 1 part of cement. If the maximum size of the gravel is 1/2 inch, the proportions may be 1 part of cement, 2 parts of sand, and 3 parts of gravel. If the maximum size of the gravel is 3/4 inch, the proportions may be 1 part of cement, 2 parts of sand, and 3 1/2 parts of gravel. It is necessary to make the mixture by mixing trial batches. Spread the floor and spread the dry cement and sand thoroughly with a shovel. Then spread the

gallons of water to 1 sack of Port-land cement, 2 parts of sand, maximum size of the gravel is 2 parts of cement, 2 parts of sand, exact amount of sand and gravel workable may be determined by spreading the mixture evenly on a wooden board and turning it over with a shovel until they are well mixed. Turn the cement and gravel in an even layer on the

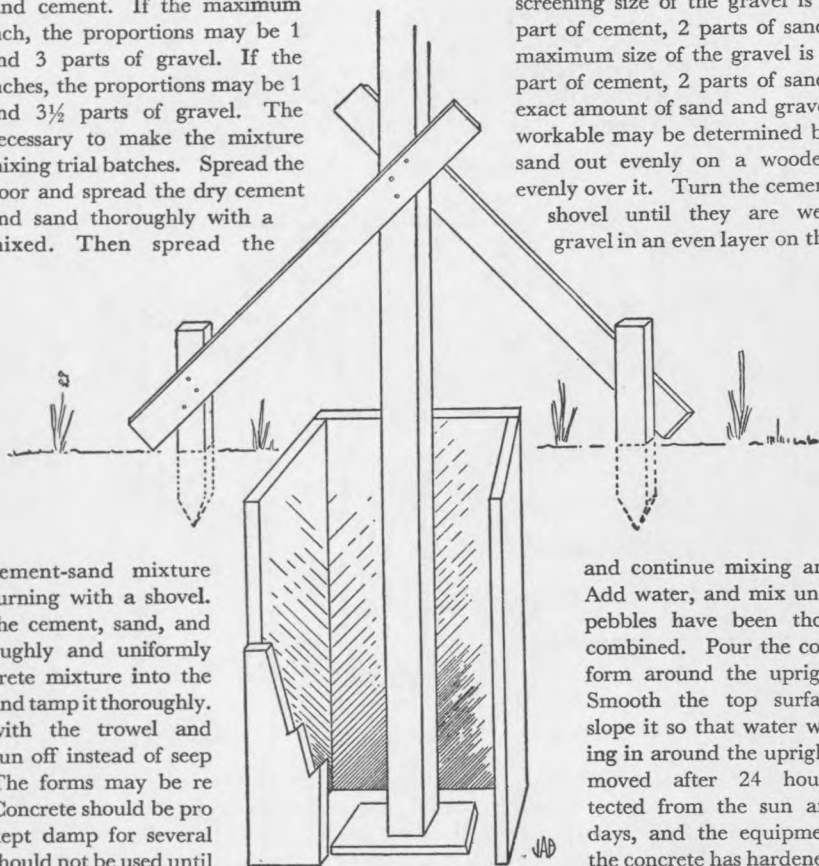

cement-sand mixture turning with a shovel. Spread the cement, sand, and gravel thoroughly and uniformly. Pour the concrete mixture into the forms and tamp it thoroughly. Smooth the top surface with the trowel and run off instead of seep. The forms may be removed after 24 hours. Concrete should be protected from the sun and kept damp for several days. The equipment should not be used until

and continue mixing. Add water, and mix until pebbles have been thoroughly combined. Pour the concrete around the upright. Smooth the top surface so that water will run off around the upright. The forms may be removed after 24 hours. The equipment should be protected from the sun and kept damp for several days. The concrete has hardened.

FIG 12

MATERIAL NEEDED FOR SWING

Rope: Waterproof manila rope, 3/4 in. in diameter and about 25 ft. long (length depending upon height of child and kind of swing).

Swing seat: 1 piece of maple or birch, 1 1/4 in. thick, 8 in. wide, and 24 in. long (fig. 13).

Other kinds of swings shown require the following material:

1 pair of galvanized steel or aluminum rings 1 in. thick and 8 in. in diameter (fig. 14).

1 automobile tire (fig. 15).

1 pair of rings made of rubber hose or bicycle tires (fig. 16).

1 piece of log 21 in. long and 5 in. in diameter, and balancing rung of oak, ash, or hickory, 21 in. long and 1 1/4 in. in diameter, for standing-log swing (fig. 17).

Rope for climbing, 2 in. in diameter and approximately 14 ft. long (fig. 18).

CONSTRUCTION OF SWING

The safest method of constructing the swing is to use special metal fittings (p. 16), such as a 6-inch hooked bolt (fig. 19) to attach the rope to the cross beam; a galvanized thimble (fig. 20) through the hook to prevent wear on the rope; and a clamp (fig. 21) to fasten the rope. If a bolt cannot be bought already hooked, have a blacksmith bend a heavy, threaded bolt into a J-shaped hook, and put the thimble through the hooked end of the bolt. Bore a hole through the cross beam. Put the threaded end of the bolt up through the hole in the cross beam and fasten the nut with a wrench, using a washer against the wood. As the bolt is screwed into the cross beam, the hooked end will be forced into the wood so that it cannot pull loose (fig. 22). (It is important to use the washer, even though it is not shown in the drawing.)

Pull one end of the rope through the hook so that the rope rests on the thimble, and fasten the end of the rope with the black enameled clamp, as in figure 22. A bowline knot may be used (fig. 23), but the clamp is a more permanent means of fastening the rope to the cross beam.

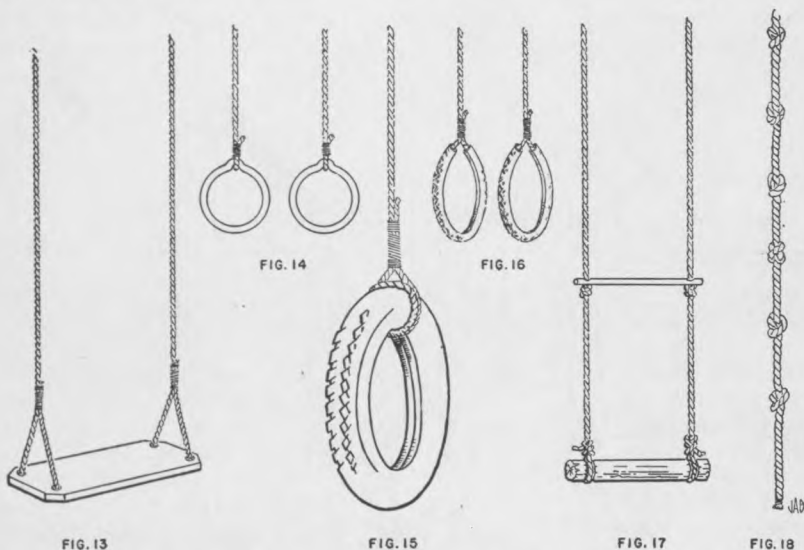

The swing seat should be low enough for the small child to touch the ground with his whole foot, about 12 inches from the ground. For older children, 20 or 22 inches is the usual height. For the small child it is better to drill four holes in the swing seat, one in each corner, and run the rope through the holes (fig. 25). Cut off the corners of the swing seat. Put the rope through the holes in the swing seat and fasten by wrapping the ends tightly to the rope (fig. 25) with marline (a cord that can be bought at a hardware store or a marine supply house). Galvanized wire is often used to wrap rope, but the ends must be fastened carefully and inspected often to prevent the child's getting scratched. The kind of clamp that is used to fasten the rope to the cross beam cannot be used here, because children might get hurt on the metal end.

An effective way of fastening the rope to the hook in the cross beam and to the swing seat is to splice the rope. Usually the company that sells the rope will do the splicing. If this method is used, however, the swing cannot be adjusted to different heights.

The swing may be a standing-log swing (fig. 17), designed to develop the arches of the feet, or a pair of flying rings for strengthening arm and shoulder muscles. For the small child, rings made of rubber hose or bicycle tires (fig. 16) slipped over the rope and fastened

tightly will serve very well, but the older, more active child will need metal rings (fig. 14), as the hands will not slip on rubber easily enough for a comfortable change of grip.

An automobile tire swing (fig. 15) is popular and can be used in many ways. A casing

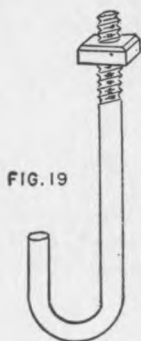

FIG. 19



FIG. 20



FIG. 21

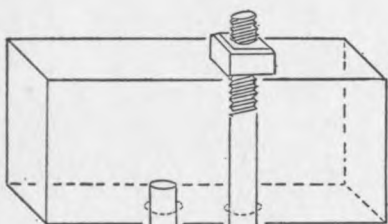

FIG. 22

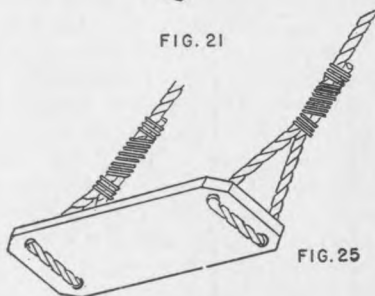

FIG. 25



FIG. 23



FIG. 24

from which the inner tube and valve have been removed is firmly fastened to a single rope. A used tire is satisfactory, if it is not worn through and the fabric is not thin.

The climbing rope is a heavy single rope in which knots are tied, 9 to 14 inches apart, the distance depending upon the size of the child who is to use the rope (fig. 18).

MATERIAL NEEDED FOR CLIMBING BARS

Bars: 5 straight-grained maple, hickory, or birch bars, $1\frac{1}{4}$ in. in diameter, 4 ft. long.

CONSTRUCTION OF CLIMBING BARS

The bars can be bought, finished, from a lumber company or a planing mill. Bore holes $1\frac{1}{4}$ inches in diameter, 12 inches apart, in both uprights of the frame (figs. 10 and 26). Sandpaper the holes enough to permit the bars to enter. Drive the bars through the holes with a heavy block of wood and a hammer. The bars should fit in the holes so tightly that they cannot slip out or turn in the child's hands. (See fig. 10, p. 13.)

The climbing bars will be enjoyed by children under 5. One end of the play plank may be placed on one of the lower bars and the other end on the ground or on a box for a walking or bouncing plank. One end of the plank may be placed on a higher bar to make a slide. The cleat on the sliding plank will prevent its slipping. (See description of play plank, pp. 11-12.)

When the child is older, the wooden bars may be removed by sawing them off close to the upright, and a piece of 1-inch pipe placed through the upright for a horizontal bar. This bar should be 1 or 2 inches higher than the child's extended finger tips and should be bolted to the uprights. This may be done by having holes $\frac{7}{16}$ inch in diameter bored through the pipe 2 inches from each end. Bore a $1\frac{1}{2}$ -inch hole in each upright through which to place the pipe; then at right angles to the first hole in each upright bore another hole $\frac{7}{16}$ inch in diameter, exactly intersecting the first hole at the center. Put the bar in place and bolt it with $\frac{3}{8}$ -inch carriage bolts and washers through upright and bar (fig. 27, p. 18).

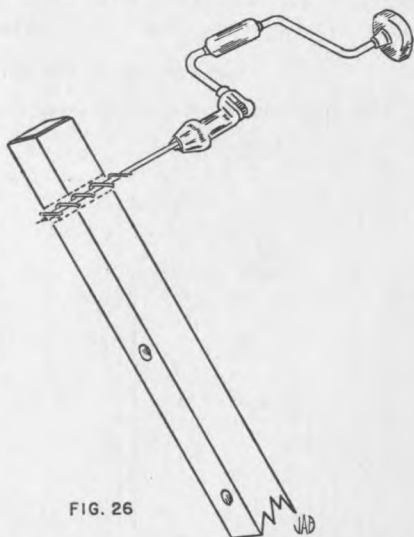

FIG. 26

SWING, RINGS, TRAPEZE, AND BAR

MATERIAL NEEDED FOR FRAME

Uprights for swing: 2 pieces of No. 1 Common Douglas fir or southern yellow pine, 4 in. thick, 6 in. wide, and 14 ft. long.

Cross beam for swing: 1 piece of No. 1 Common Douglas fir or southern yellow pine, 4 in. thick, 6 in. wide, and 14 ft. long.

Upright for horizontal bar: 1 piece of No. 1 Common Douglas fir or southern yellow pine, 4 in. thick, 6 in. wide, and 9 ft. long.

Braces: 4 pieces of No. 1 Common Douglas fir or southern yellow pine, 2 in. thick, 4 in. wide, and 10 ft. long (not required if uprights are set 3 ft. in concrete).

Nails: 1 pound of 20-penny common nails or carriage bolts.

(NOTE.—The frame may be made of 3-in. pipe of approximately the same lengths as the lumber.)

CONSTRUCTION OF FRAME

See directions for constructing frame of swing, page 13.

MATERIAL NEEDED FOR SWING, RINGS, AND TRAPEZE

Rope: Waterproof manila rope, $\frac{3}{4}$ in. in diameter (length depending upon height of child; approximately 25 ft. will be needed for swing, 15 ft. for rings, and 15 ft. for trapeze).

Swing seat: 1 piece of maple or birch, $1\frac{1}{4}$ in. thick, 8 in. wide, and 24 in. long.

Rings: 2 galvanized steel or aluminum rings, 1 in. thick, 8 in. in diameter.

Trapeze: 1 straight-grained maple, birch, or hickory bar, $1\frac{1}{4}$ in. in diameter, 24 in. long.

CONSTRUCTION OF SWING, RINGS, AND TRAPEZE

See directions for constructing swing, page 15.

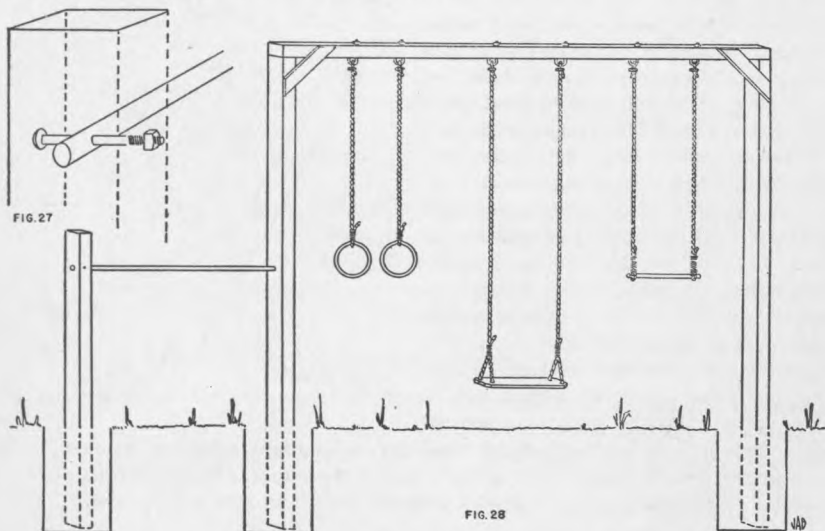

MATERIAL NEEDED FOR HORIZONTAL BAR

Bar: 1 piece of pipe, 1 in. in diameter, 6 ft. long.

Bolts: 2 carriage bolts, $\frac{3}{8}$ in. in diameter.

CONSTRUCTION OF HORIZONTAL BAR

See directions for attaching climbing bars to uprights, page 17.

It is especially important that this combination of swing, rings, trapeze, and bar (fig. 28) be well constructed. Inspect it frequently. The combination is a good piece of apparatus for a large yard. It may be placed across the end of a yard where it will cover a space about 20 feet long and 18 feet wide. If several children of about the same age use the equipment, three swings may be preferred. The attachments may be varied to suit the children's ages and interests.

HORIZONTAL LADDER

In this piece of equipment the horizontal ladder is supported by two perpendicular ladders. The easiest way to construct it is to buy a 30-foot ladder, either single or extension, and cut it into three sections. Set two of the sections in concrete (see directions on p. 13) for the perpendicular ladders, and place the other section across the top for the

horizontal ladder. For older children, the horizontal ladder should be firmly bolted to the uprights at both ends (fig. 29). For children under 5, the horizontal ladder can be made adjustable. Cut a groove in the frame at each end of the horizontal ladder,

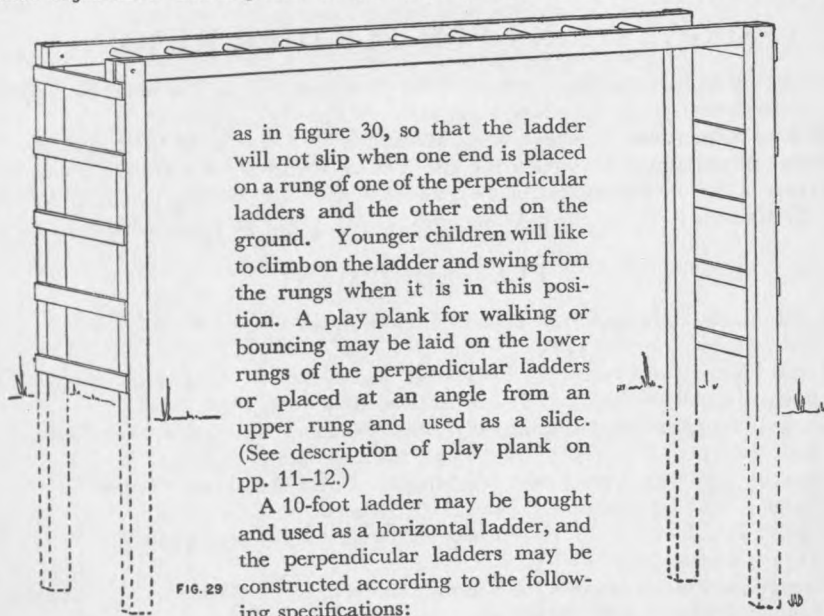

FIG. 29

as in figure 30, so that the ladder will not slip when one end is placed on a rung of one of the perpendicular ladders and the other end on the ground. Younger children will like to climb on the ladder and swing from the rungs when it is in this position. A play plank for walking or bouncing may be laid on the lower rungs of the perpendicular ladders or placed at an angle from an upper rung and used as a slide. (See description of play plank on pp. 11-12.)

A 10-foot ladder may be bought and used as a horizontal ladder, and the perpendicular ladders may be constructed according to the following specifications:

MATERIAL NEEDED FOR PERPENDICULAR LADDERS

- Uprights:** 4 pieces of No. 1 Common Douglas fir or southern yellow pine, 2 in. thick, 4 in. wide, and 9 ft. long.
- Braces:** 4 pieces of No. 1 Common Douglas fir or southern yellow pine, 2 in. thick, 4 in. wide, and 10 ft. long (not required if uprights are set 3 ft. in concrete).
- Rungs for uprights:** 10 pieces of maple or birch, $\frac{3}{4}$ in. thick, 3 in. wide, 20 in. long.
- Nails:** 1 pound 16-penny common nails.
- Bolts:** Carriage bolts, $\frac{3}{8}$ in. in diameter, 5 in. long.

CONSTRUCTION OF PERPENDICULAR LADDERS

Set uprights in concrete (see directions on pp. 13-14). Bolt the rungs tightly to the uprights about 10 inches apart.

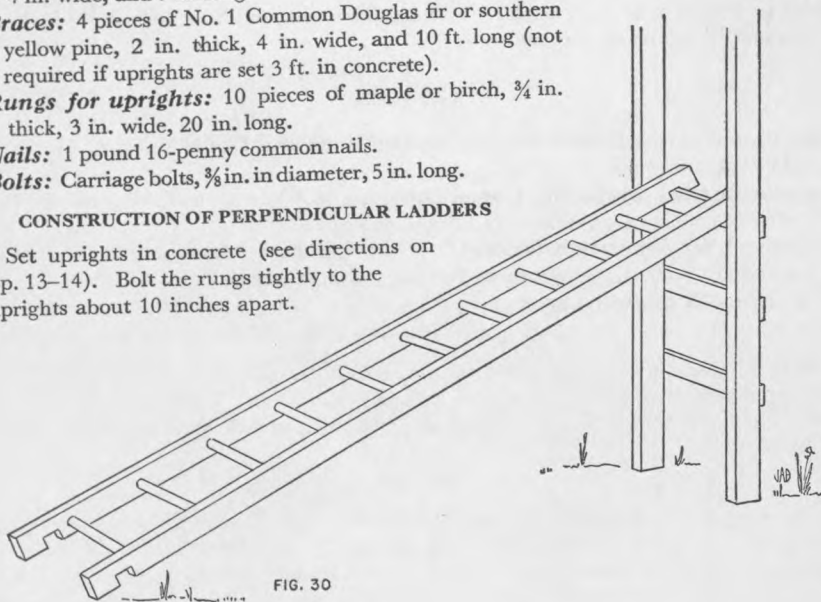

FIG. 30

SUGGESTIONS FOR FURTHER READING

- Busy Childhood**; guidance through play and activity, by Josephine C. Foster. D. Appleton-Century Co., New York, 1933. 303 pp.
- Play in Education**, by Joseph Lee. Macmillan Co., New York, 1915. 500 pp.
- Some Educational Activities for the Young Child in the Home**, by Rowena Hansen. U. S. Department of the Interior, Office of Education Pamphlet No. 51. Government Printing Office, Washington, D. C., 1934. 23 pp. 5 cents.

PLAY EQUIPMENT

- Home-Made Toys and Play Equipment**, by Agnes Tilson. Published by Farmer's Wife, St. Paul, Minn., 1933. 23 pp.
- Home Play**. Playground and Recreation Association of America (now National Recreation Association), 315 Fourth Avenue, New York, 1928. 48 pp.
- Home Playground and Indoor Playroom**. National Recreation Association, 315 Fourth Avenue, New York, 1936. 9 pp. Mimeographed.
- Housing and Equipping the Washington Child Research Center**, by Mary Dabney Davis and Christine Heinig. U. S. Department of the Interior, Office of Education Pamphlet No. 13. Government Printing Office, Washington, D. C., 1930-24 pp. 5 cents.
- Permanent Play Materials for Young Children**, by Charlotte G. Garrison. Charles Scribner's Sons, New York, 1926. 122 pp.
- Play and Play Materials for the Preschool Child**, by Harriet Mitchell. Publication No. 45, Canadian Council on Child and Family Welfare, Ottawa, 1934. 62 pp.
- Play and Playthings**, by Anna W. M. Wolf and Edith London Boehm. Child Study Association of America, 221 West Fifty-seventh Street, New York, 1930. 11 pp.
- Two to Six**, by Rose H. Alschuler. William Morrow & Co., New York, 1933. 160 pp. (Includes a section on play materials.)

GAMES

- Games and Game Leadership**, by Charles F. Smith. Dodd, Mead & Co., New York, 1932. 658 pp.
- Games for the Playground, Home, School, and Gymnasium**, by Jessie H. Bancroft. Macmillan Co., New York, 1909. 463 pp.
- Handbook for Recreation Leaders**. U. S. Department of Labor, Children's Bureau Publication No. 231. Government Printing Office, Washington, D. C., 1936. 121 pp. 15 cents. (A manual of games.)

NOTE.—Many of the State universities or agricultural colleges issue mimeographed or printed material on the subject of play and play equipment. Residents of a State can obtain such publications free or at small cost by writing to their State university or agricultural college.



These children are playing with a sand box, play planks, a packing box, and a wagon. In the picture on the cover 5-year-old children are using perpendicular ladders to which a slanting ladder has been bolted.

Both pictures are from photographs taken at the National Child Research Center, Washington, D. C.