

U. S. DEPARTMENT OF LABOR
CHILDREN'S BUREAU

JULIA C. LATHROP, Chief

CHILD-WELFARE EXHIBITS

TYPES AND PREPARATION

BY

ANNA LOUISE STRONG, Ph. D.

MISCELLANEOUS SERIES No. 4

Bureau Publication No. 14



WASHINGTON
GOVERNMENT PRINTING OFFICE

1915

Room for Motion Pictures

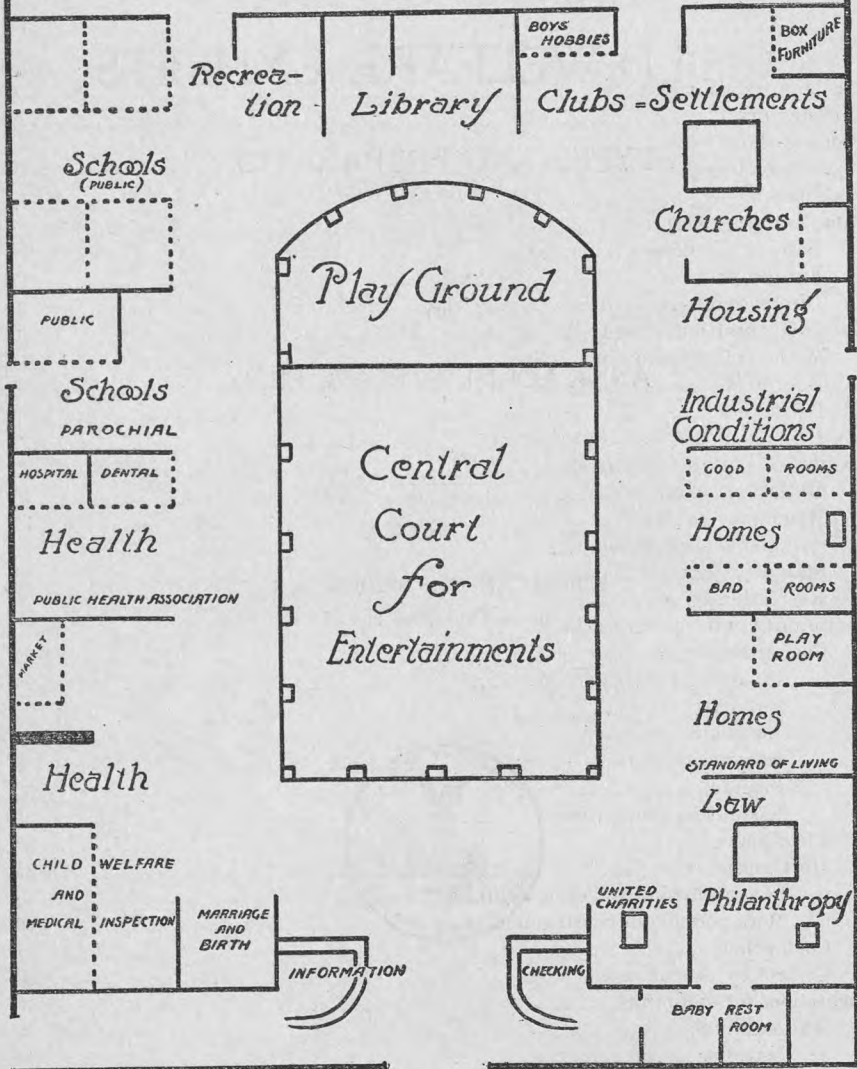

FRONTISPIECE.—TYPICAL FLOOR PLAN OF A CHILD-WELFARE EXHIBIT (HELD IN ROCHESTER), SHOWING CENTRAL COURT, WIDE AISLE, LARGE SECTIONS ARRANGED BY SUBJECTS.

TABLE OF CONTENTS.

	Page.
Letter of transmittal.....	5
Introductory.....	7
Scope of the exhibit.....	8
Use of traveling exhibits.....	10
Wall panels.....	12
Infant-welfare exhibit.....	11-13
Baby in the home.....	12
Exhibit on food.....	13
Directory of organizations.....	13
Children's health conference.....	13-19
Method of organization.....	14
Equipment needed.....	16
Baby week.....	16
Permanent centers—State circuits.....	17
Exhibit on children's interests.....	19-23
Method of organization.....	19
Home-play exhibit.....	21
Supplementary exhibits.....	22
State-wide exhibit.....	22
Recreation survey.....	22
Community child-welfare exhibits.....	23-32
Committee organization.....	24-27
Finance, or ways and means.....	24
Publicity.....	24
Installation.....	25
Hospitality and explainers.....	25
Program.....	26
Exhibiting committees.....	26
Floor plans.....	27
Unit construction.....	28-31
Construction of traveling exhibits.....	28
More permanent construction.....	30
Color scheme.....	31
Control by executive office.....	32
Suggestions for exhibitors.....	32-46
Wall exhibits.....	33-36
Lettering.....	34
Photographs and illustrations.....	34
Transparencies.....	35
Three-dimension exhibits.....	36-42
Models.....	36
Moving models and electrical devices.....	39

	Page.
Suggestions for exhibitors—Continued.	42-46
Living exhibits.....	42
Explainers.....	43
Demonstrations.....	44
Program committee.....	46
After the exhibit.....	49
Appendix 1. Child-welfare exhibits owned by State departments, January 1, 1915.....	52
Appendix 2. Record of Children's Health Conference.....	54
Appendix 3. Table of weights and measures.....	55
Appendix 4. Announcement and entry form of Seattle Junior Exhibition.....	57
Appendix 5. Bureau's exhibit at Panama-Pacific International Exposition....	

ILLUSTRATIONS.

- Frontispiece. Typical floor plan of a child-welfare exhibit (held in Rochester), showing central court, wide aisle, large sections arranged by subjects.
- No. 1. Children's Health Conference. Doctor, nurse, parent, and child are separated from the general public by a glass wall through which the examination can be seen.
- No. 2. Home-play exhibit.
- No. 3. Balance beam and slide in home-play exhibit.
- No. 4. Wall panel from the exhibit of the Children's Bureau, showing the use of cartoons.
- No. 5. Wall panel from the exhibit of the Children's Bureau, showing an arrangement of photographs and statements pasted on a larger background which forms the unit of construction.
- No. 6. Wall panel from the exhibit of the Children's Bureau, showing a combination of photographs and cartoons.
- No. 7. Wall panel on infant care.
- No. 8. Wall panel on infant care.
- No. 9. Wall panel on prenatal care.
- No. 10. Model made for a child-welfare exhibit by a vocational class in the Rochester public schools.
- No. 11. Dental exhibit comprising photographs, statements, lantern lecture, dental equipment, models of teeth, and a demonstration of dental examination, all in one 8 by 12 space, made by the Rochester Dental Society.
- No. 12. Starting a fly campaign at the Rochester Child-Welfare Exhibit. A combination of "living exhibit" with charts.
- No. 13. A good exhibit for a library in a community child-welfare exhibition is a children's room in operation.
- No. 14. Diagram of wall panel composed of cards.
- No. 15. Cross section of an illusion. (Side view with door removed.)

LETTER OF TRANSMITTAL.

U. S. DEPARTMENT OF LABOR,
CHILDREN'S BUREAU,
Washington, D. C., September 20, 1915.

SIR: I transmit herewith a bulletin on Child-welfare Exhibits: Types and preparation, by Dr. Anna Louise Strong, exhibit expert of the Children's Bureau.

The exhibit has proved, in recent years, an important means for the widespread publication of facts. Especially effective have been the uses of this form of publication in relation to child and infant welfare. The Children's Bureau receives many letters of inquiry from organizations and individuals desiring to hold such exhibits; and it is in answer to inquiries of this kind that this bulletin has been prepared.

Respectfully submitted.

JULIA C. LATHROP, *Chief.*

Hon. WILLIAM B. WILSON,
Secretary of Labor.

ST. LOUIS, MO., [illegible]

[illegible]

[The body of the document contains several paragraphs of text that are extremely faint and illegible due to the quality of the scan. The text appears to be a formal letter or report.]

CHILD-WELFARE EXHIBITS.

INTRODUCTORY.

In the past five years there have occurred in nearly every part of the United States three distinct series of exhibits all dealing with subjects which may be classed under the general head of child welfare. The New York Child-welfare Exhibit, held in January, 1911, aimed to show all influences affecting the welfare of children in the city of New York, and gave rise to a series of similar exhibits in Chicago, Kansas City, Northampton, St. Louis, Buffalo, Montreal, Louisville, Providence, Knoxville, Rochester, New Britain, Peoria, Toledo, Seattle, Indianapolis, and Dublin (Ireland), and many smaller places.

The Philadelphia Baby-Saving Show, in May, 1912, gave its attention to one aspect of child welfare—that of baby saving, covering this in much greater detail than had previously been done. This show led not only to other baby-saving exhibits but to an enrichment of the series of larger child-welfare exhibits as far as the subject of infant welfare was concerned. A further enrichment came from the Junior Exhibitions, held in Cleveland and San Francisco, a display on a large scale of objects made by children; and from the boys' hobby shows of the Young Men's Christian Association, dealing with the special interests of adolescent boys. The children's health conference, consisting of a free physical examination for children, held in Knoxville, Tenn., in September–October, 1913, in the children's building of the National Conservation Congress, established a technique for still another feature of a child-welfare exhibit. Each of these exhibits has been held at times alone and at other times as part of a larger child-welfare exhibit.

The demand for an exhibit may arise in a community in many ways. A mother's club or infant-welfare station may desire some new and graphic way of teaching mothers the methods of infant care; a settlement or club may wish to interest parents more vitally in the development of the growing boy and girl; several children's philanthropies may wish to explain their work to the public; or a group of representative citizens from all these organizations may feel

that the time has come for a graphic presentation of all the conditions that affect the well-being of the community's children, so that the whole community may know those conditions and take action concerning them.

For all these purposes the exhibit has proved a useful method of popular education. Comments of parents, teachers, and visiting nurses after the exhibit show conclusively that many homes are reached and influenced by the sections intended especially for parents. In securing community aims through publicity the exhibit has shown itself equally effective. New laws or new machinery for law enforcement or community administration have been secured by practically every large child-welfare exhibit. A comprehensive exhibit of this kind should combine both the appeal to the parent and that to the citizen, using each to reenforce the other. In this respect it offers a peculiarly democratic approach to the problems involved in the welfare of the child, since it takes as point of departure not the "poor child" nor the "bad boy," but all children, leading the parent to that interest in community action through which alone his own child may be safeguarded and the citizen to a knowledge of the individual problems of heredity, ignorance, and poverty on the adequate solution of which depends the community's future.

At first only the larger cities felt able to undertake the expense of a child-welfare exhibit, which varied from \$80,000 in New York to \$3,000 or \$4,000 in Toledo, Seattle, and Rochester, and even in a small community like Northampton, Mass., was as high as \$847. But with the improvement of exhibit technique and with the construction of many traveling exhibits owned by Federal and State authorities or by national organizations practically any community can now hold some type of child-welfare exhibit for very little cost.

SCOPE OF THE EXHIBIT.

The first thing to be decided when a demand arises for an exhibit dealing with questions of child welfare is the scope and exact purpose of the exhibit.

Is the exhibit to be part of a larger exposition? If so, it will be conditioned in the choice of its field by the classification already made by the exposition authorities. Even if no external situation compels the limiting of the field, reasons of economy, whether of time, money, or effort, may make it wiser to undertake only one part of the vast subject of child welfare and cover that part with greater detail.

Care in naming is desirable if the exhibit is to reach its proper audience. The tendency to use the title "child-welfare exhibit" for small exhibits which deal with the care of babies, home play, child-

helping agencies, or any one partial aspect of the whole question of the child's welfare leads to many misconceptions. It is far better to give these exhibits more specific names, such as infant-welfare exhibit, baby-saving show, child-helping exhibit, children's health conference and exhibit. An exhibit which covers a large variety of subjects of special interest to parents, such as infant care, food, play, interests, and ideals, but which does not include any reference to community problems, may perhaps be designated by the general name of "child-welfare exhibit," although even in this case "the child in the home" would seem a better name. If the name of a city or State is used as a prefix, as "Kansas City Child-Welfare Exhibit," the public has a right to expect a well-rounded presentation of the whole question of the welfare of the community's children, including health, education, recreation, and the many problems that arise in dealing with the defective, dependent, and delinquent child. Further description of many different types of exhibits suited to varying needs will be given later; here it will be sufficient to note the special situations which call for special kinds of exhibits.

If the main purpose is to arouse parents to a knowledge of the physical needs of their own children and the way to care for those needs, a children's health conference combined with a small exhibit on the care of the baby and the preparation of food is perhaps the most direct method of accomplishing this end. A conference requires for its fullest success the cooperation of the county medical society, the local women's organizations, and the local authorities on domestic science. If, on the other hand, the attention of parents should be directed toward the mental and social needs of the growing child, a junior exhibition or exhibit of children's interests is perhaps the most desirable type of exhibit. A playground or school or any organization which has direct access to a large number of children may manage such an exhibit, but for a many-sided display it is well to include other organizations dealing with the interests and ideals of children, such as the library, the Young Men's Christian Association, the Young Women's Christian Association, the Camp Fire Girls, the Boy Scouts, and any boys' and girls' clubs that may exist. A combination of a children's health conference and a junior exhibition might make a fairly comprehensive exhibit on "the child in the home," the purpose of which would be to stir parents to a knowledge of what they might do to encourage the well-rounded development of their children.

If, however, it is desired not only to help individual parents, but to secure needed legislation or community action for the welfare of children, then the exhibit must be more extended in scope. It may be a baby-saving show, emphasizing the need of birth registration, proper inspection of milk, a child-hygiene division in the board of health, or similar needs, and using the children's health conference

as one feature among many others. Or it may be a child-welfare exhibit, modeled on the lines of the large general exhibits held under that name and containing divisions on health, schools, recreation, moral and religious training, philanthropy, law, industrial conditions, etc., and showing the work of many organizations as well as many needs, such as a new child-labor law, more playgrounds, children's work in the library, or medical inspection in the schools.

An exhibit on a specific subject, intended to be of use to parents, can well be held by any woman's club, settlement, church, playground, school, or similar organization. On the other hand, a community child-welfare exhibit, designed to move the community to action, should include on its governing committee representatives of all agencies dealing with children—the schools, the playgrounds, the board of health, the various philanthropies, as well as members representing, perhaps unofficially, any large religious or industrial groupings whose cooperation is needed for permanent results.

USE OF TRAVELING EXHIBITS.

One of the first suggestions made when a child-welfare exhibit is planned is to save expense by collecting as many exhibits as possible from National and State sources. To meet this demand many State universities and State health departments have prepared traveling exhibits, usually available for the cost of transportation. Many national educational and philanthropic organizations have traveling exhibits, which they loan for a nominal rental.

The list of State departments—State health departments, extension departments of State universities and of State agricultural colleges—owning exhibits on January 1, 1915, will be found in Appendix 1. Progress in this field is so rapid that no local committee need hesitate to inquire of State departments which do not appear in this list.

The extent to which it is wise to make use of borrowed exhibits is a question to be considered seriously by the local executive committee. The advantages are plain. They save a heavy expense of photographs, cartoons, and lettering, and they are probably designed with more care and with access to a wider range of facts than can be secured by a local committee in the rush preceding an exhibit. But the disadvantages are equally plain. They rarely apply with great force to peculiarly local needs; they fail to arouse local effort and enthusiasm.

An exhibit designed primarily for parents may venture to borrow all its wall charts on infant care from some authoritative source. Local interest will be sufficiently excited by the examination of local children and the collection locally of the baby's clothing, bathing

and sleeping arrangements, and local exhibits on food and home play.

But in a larger child-welfare exhibit, which aims to secure community action, it is a serious mistake to send out hastily for collections of borrowed exhibits, however good these may be. The local exhibit should first be carefully planned under appropriate subjects and borrowed material used sparingly and only when it will give force and wider background to important local facts. The work of local committees, even when crude, is of such educational value that it is often worth more to the community than the technically better work of outsiders. This is not merely because it contains local facts and catchwords and describes local needs, but because the process of collecting those facts, analyzing them, stating them graphically, and coming to conclusions concerning them, may mean more for the community's future, when done by a local committee, than the portrayal of the facts in the most effective exhibit form. A committee on health, for instance, or on recreation, or on child labor comprises many factions with many views; its members possess many isolated bits of knowledge. Under the pressure of a coming exhibit factional discussion must be brought to some conclusion; the bits of knowledge, more or less vague before, must be welded into a community program, clear and definite, which the committee is willing to present to the public. If this is carefully done, then through this committee work, before a single wall exhibit is lifted or a single model in place, the child-welfare exhibit may have more than justified itself.

INFANT-WELFARE EXHIBIT.

Perhaps the simplest and most easily planned type of exhibit is the small infant-welfare exhibit held in connection with State and county fairs, baby contests, or children's health conferences. Such an exhibit may be designed merely to give information to the mothers of a community or it may have the more definite object of arousing interest in a proposed infant-welfare station or child-welfare center. It may be held by an infant-welfare committee of a woman's club, by a settlement, a visiting-nurse association, or similar organization, and may be planned to influence a small town, a country district, a city neighborhood, or an entire city.

The organization of an exhibit intended to include all the activities of a large city will be considered later under the head of community child-welfare exhibits. For smaller exhibits, held by an infant-welfare committee or association, little formal organization is necessary. Each main subdivision of the exhibit should be placed in charge of an individual or a small committee; these are named and described later. Questions of place, publicity, lectures, and bor-

rowed exhibits may or may not need attention by special committees or designated individuals; frequently in small exhibits such questions already have been determined by the circumstances which called the exhibit into being.

WALL PANELS.

The question must be decided whether the panels shall be borrowed or shall be prepared under medical direction. Living demonstrations and actual objects form by far the most effective part of any exhibit. These can be prepared locally, however, with better results than attend any traveling exhibit. Wall panels, on the other hand, while in many ways the least effective part of an exhibit, are expensive and difficult to prepare, but they form a desirable addition and one which with advantage can be loaned again and again.

If it is decided to borrow exhibit material in the form of wall exhibits, application may be made to the local State board of health, or the State university, many of which possess lending exhibits on infant welfare. (See Appendix 1.) The Children's Bureau also sends out small collections of wall panels and lantern slides on this subject, though they in no sense form a complete exhibit or a substitute for local effort. The following organizations have traveling exhibits on infant welfare: The Association for the Study and Prevention of Infant Mortality, 1211 Cathedral Street, Baltimore, Md.; the Russell Sage Foundation, 130 East Twenty-second Street, New York City; and the National Child-Welfare Exhibit Association, 30 East Forty-second Street, New York City.

In case it is decided to prepare the panels locally with the advice of the local society doing infant-welfare work or of a committee of physicians, various methods of preparation, dependent upon the amount of money to be expended, may be used. (See section on Wall Exhibits, p. 33.)

Among the many forms of locally prepared exhibits which are effective without being costly may be mentioned the following:

BABY IN THE HOME.

[Prepared by local society doing infant-welfare work or by women's organizations under medical direction.]

- Clothing for baby.
- Sleeping arrangements.
- Bathing arrangements.
- Toys—plain, unpainted.
- Baby killers—long-tubed bottles, flies, etc.
- Scales for weighing baby.
- Good and bad carriages.
- Any good ideas for the care of babies.

For this exhibit local stores would lend articles, but the choosing of these articles should be done under a responsible committee of people doing infant-welfare work. The exhibit might profitably show home-made outfits at minimum cost, as well as good ideas for families of fair income.

EXHIBIT ON FOOD.

[Under local committee of children's specialists and domestic-science teachers.]

- (a) Modification of milk—objects and demonstrations.
- (b) Demonstration of preparing various foods for young children.
- (c) Right food for babies 9 months to 18 months. (Sample meals for one day.)
- (d) Right food for children 18 months to 2 years.
- (e) Right food for children 2 to 3 years.
- (f) Good school lunches.
- (g) An exhibit of a good and a bad Saturday-night family market basket.
- (h) A good and a bad grocery, preferably prepared by the local food inspector or the housewives' league.

DIRECTORY OF ORGANIZATIONS.

Each organization dealing with babies should be allowed one panel on which to state, in briefest possible form, the precise place it occupies in the infant-welfare work of the community. This should be done under the supervision of a committee composed of representatives of all the organizations.

Every organization planning an infant-welfare exhibit should consider the possibility of holding a children's health conference in connection with it; in fact it may prove advisable to make the conference the central feature of the exhibit. The organization of such a conference is so important that it must be considered at greater length.

CHILDREN'S HEALTH CONFERENCE.

An activity frequently combined with an infant-welfare exhibit, but important enough to deserve more detailed description, is the children's health conference, consisting of a free physical examination of children under 15 years of age. A record is given each parent containing a statement of the child's condition and any general advice that seems needed regarding diet, exercise, and general hygiene. A conference of this type formed the central feature of the exhibit of the Children's Bureau at the Panama-Pacific Exposition, San Francisco, 1915. (See illustration No. 1.)

This conference is not a clinic, in that no sick children are admitted and no treatment or prescriptions given. Where there is need for treatment the case is referred to the family physician or to a clinic, or the type of specialist to be consulted is indicated on the record. The weight and height of each child is compared with the average for its age. (See Appendix 3.) Nor is it a "contest," since children are not graded or scored on a percentage basis—a method which would require the presence of several specialists—and consequently no comparing of children is possible. The kind of children that come, the needs which are found, and the type of advice given are indicated in the set of typical records found in Appendix 2.

The particular method of this conference was foreshadowed in the many local child-welfare exhibits in which local infant-welfare organizations offered a free physical examination for all babies as a part of their exhibit. It was not, however, a consciously distinct plan of baby-saving work until the National Conservation Exposition in Knoxville, Tenn., September-October, 1913, where a children's building was managed by a committee composed of representatives of the Children's Bureau, the Russell Sage Foundation, the National Child-Welfare Exhibit Association, the National Child-Labor Committee, and other National, State, and local organizations. As a contribution to the joint exhibit the Russell Sage Foundation gave the services of Miss Ellen C. Babbitt, who planned and organized the Children's Health Conference, which was later conducted by Dr. Frances Sage Bradley. It was in continuous operation for two months, and drew children not only from Knoxville but from remote country and mountain districts. It was immediately followed by similar conferences in Peoria, Atlanta, Toledo, and Dublin (Ireland), all held in connection with local child-welfare exhibits. The Dublin conference attracted wide attention and gave promise of spreading the movement to other countries in Europe had it not been for the outbreak of the war.

METHOD OF ORGANIZATION.

In some of the cities children were examined by a single out-of-town physician, paid for the entire time; in others by members of a committee of the local medical society. Both of these methods have their strong and weak points. The examination by local physicians can be conducted for less expense and helps to arouse the interest of the local medical society in infant welfare. It is not, however, adapted to conferences lasting more than a short time, and it raises several problems. Many good children's specialists have had little experience in giving simple advice helpful to mothers. The local medical society is without doubt the organization which

should take part in calling the conference and in directing its policy, deciding after careful consideration whether the examinations shall be made by its own members or shall be under the charge of a physician from another city.

The conference held in Jacksonville, November-December, 1914, in connection with the annual meeting of the American Public Health Association, deserves detailed description, since it combines some of the good points of both methods. It was organized at the request of the city board of health and the county medical society, but carried on under a physician with previous experience in conference work but with no local connections, who came three weeks before the opening to organize the work. Local physicians and dentists gave valuable assistance, as the work was too great to be handled by one person. Three school nurses were put at the disposal of the conference for the entire time.

A conference of this type requires the organization of four committees:

1. A committee of the medical society, which secures the equipment and governs the policy of the conference, decides on the place, hours, age limit, and form of record.

2. A committee of the dental society, which secures the equipment and takes charge of the examination of children's teeth.

3. A publicity committee, on which are represented the press, the business men's organizations, and the women's clubs. It is especially important that information about the conference be widely spread among mothers. This can sometimes be done partly through the schools.

4. A committee on exhibits. If the conference is part of a larger exhibit with its own committees, special committees in the conference on publicity and exhibits would be unnecessary.

In Jacksonville the exhibits connected with the conference were prepared under a committee composed of the State chairman of public health of the Federation of Women's Clubs, the president of the Jacksonville Women's Club, and the president of the Parent Teachers' Association. This committee designated the different women's organizations, which, under the direction of the physicians in charge, prepared exhibits on baby feeding, clothing, toys, and sleeping and bathing arrangements.

With enthusiastic local cooperation most of the equipment of the conference can be borrowed or made by various women's organizations. The hall can usually be obtained free and should allow ample space for the examination of several children and a place from which the public can see what is going on, preferably through a glass wall, without coming near enough to interfere. This is of special value, as one of the main objects of the conference is to educate the public

in the value of a periodic examination made by a physician, not only after the child has entered school, but also before school age. In many communities the importance of medical inspection for school children has long been recognized; but while a few infant-welfare stations now include the oversight of children between 2 and 6 years, this period is neglected in most communities. The children's health conference shows the importance of an examination for children of all ages, in order that bad tendencies may be discovered and corrected before they become serious defects. In the Jacksonville conference the salary of the organizer and the printing of the records formed almost the only expense.

EQUIPMENT NEEDED.

The equipment needed for the examination of the children is as follows:

- Desk for examining physician.
- Table for examinations.
- Table for scales.
- Scale for infants.
- Scale and measuring rod for older children.
- Tape measures.
- Pad for examining table.
- Stork sheeting for examining table.
- Supply of sheets for both tables.
- Lavatory or substitute.
- Paper towels, soap, bichloride tablets, etc.
- Electric flasher.
- Tongue depressors.
- Stethoscope.
- Calipers.
- Toys (to amuse frightened children).
- Records.
- Summary sheet for physician's own record.
- Helpful literature for distribution.

BABY WEEK.

Following the lead of New York City and Chicago, various cities during the last year have been setting aside one week, usually in the late spring or early summer, for a special celebration in honor of the baby, during which every phase of infant-welfare work is thoroughly advertised. There is no reason why smaller towns and country districts should not also have a "baby week," using any of the many features adopted in the larger cities. Among the special features which have been used on these occasions are the following:

Special stories in all the newspapers before and during baby week.

Illuminated signs, billboard posters, window cards, streamers, and other forms of poster advertising.

Lantern slides exhibited between films in all the motion-picture houses. Educational literature distributed by school children.

Leaflets on proper clothing distributed by department stores in all packages containing infant wear; leaflets on the care of baby's bottle inserted in drug-store packages; tags on pure milk wired to milk bottles by the milk dealers.

Special advertising of baby goods by many large firms.

Lectures in a central hall and in various districts.

Flag-distribution day (first introduced in the Pittsburgh baby week). A special pennant is taken to each home in which there is a baby under a year old and fastened in the window. At the same time each mother is given an envelope of literature on the care of the baby.

House-to-house canvass for funds for the infant-welfare activities of the city. This was done in the Chicago baby week. The city was districted and assigned to various women's organizations. Contributions, even of 5 cents, were welcomed, as the main object was to interest the entire city in supporting the work for babies. A daily luncheon was held to report progress.

A baby week may well include an infant-welfare exhibit and children's health conference held in some central place, or a children's health conference may be advertised by many of the publicity methods of baby week. The difference between these two plans is merely one of naming and emphasis.

PERMANENT CENTERS—STATE CIRCUITS.

In several communities infant-welfare exhibit, or health conferences, have led to the establishment of permanent centers. In Oregon a baby health contest and exhibit, held at the State fair, led to a permanent parents' educational bureau. In Iowa it is hoped that the baby health contests and conferences, for the organization of which the State university sends a physician, will lead to a series of child-welfare centers, with regular examinations of children. In New York the exhibit of the State department of health is sent out in accordance with a definite policy, and has led in many cases to local infant-welfare stations. The work of the infant-welfare station, supplemented by instructive work by nurses in the home, has proved the most successful means for the care of those babies whose parents can not afford such regular care from a private physician. The baby is brought weekly to the station to be weighed; the mother is encour-

aged in every way to nurse the baby; when this is impossible the feeding is prescribed by the physician, and the mother is taught in her own home by the nurse how to prepare the feedings. Many communities, especially small towns and rural communities, have not as yet, however, been able to support such stations, and some substitute such as one of the other forms of permanent stations must be used.

The Parents' Educational Bureau, in Portland, Oreg., is operated by the State Congress of Mothers in three rooms in the courthouse placed at their disposal by the county commissioners. Although its origin was a baby contest, the bureau has dropped not only all prize giving but even the name of contest, finding that it detracted from the effectiveness of the work. The bureau is not an infant-welfare station, as each baby is not brought back every week. It lays emphasis on the value of a complete physical and mental examination, at least once, and preferably at intervals for every baby in the community.

Usually applications are made several weeks ahead, as only 15 to 20 children can be cared for in the one session a week, which lasts from 1 till 2.30 p. m. Six doctors, a dentist, and five general workers come for this period—all as volunteers. The children range in age from 6 months to 6 years, but in communities where there is no efficient system of medical inspection to care for school children, the age might profitably be extended. The mental examination is made first, then the general physical examination, and, finally, the examination of the nose and teeth. Four doctors are engaged in the physical examinations, in order to keep pace with the time taken by the special tests. In two years 2,270 children have been examined.

The Parents' Educational Bureau also maintains a series of lectures on infant care, a supply of free literature collected from various sources, and an exhibit of an inexpensive layette, with free patterns for young mothers. A 25-cent registration fee for each baby covers all incidental charges except the salary of a clerical worker, who answers the telephone, makes appointments, and attends to other details.

Obviously, in many rural counties, the continuous time even of one worker can not at once be secured. For such counties the temporary infant-welfare exhibit and children's health conference might well leave behind "child-welfare centers" of the type planned in Iowa. These are permanent deposit stations of such literature and exhibits as may be available, at which it is planned to hold health contests or conferences from time to time. A physician to organize and direct such conferences is sent by the extension division of the State university.

A series of county child-welfare centers might well be placed on a regular circuit, supplied from a central source with a traveling medical director, assisted by the county medical society, to conduct children's health conferences at definitely fixed dates and accompanied perhaps by a nurse to give demonstrations on the care and feeding of infants. This, in many States, would seem a step not only natural but not too difficult to take and would establish a circuit for lectures and traveling exhibits and a strong working basis for later developments.

EXHIBIT ON CHILDREN'S INTERESTS.

A playground, settlement, school, Sunday school, or any organization with access to a large number of children can hold an exhibit on children's interests at small expense. Where it is desired to reach all the parents of a large community the school system usually offers the means of accomplishing this end with little trouble.

The object of an exhibit of this type, whether known as junior exhibition, child-life exhibition, back-to-the-home exhibit, or exhibit of children's interests, is to show parents the wide extent of the interests of children and the need of supplying adequate material and tools for their expression, and thus to lay a foundation for the enrichment of home life in its contributions to the development of the growing child in body, mind, character, and social relations. Supplementary exhibits from playgrounds, libraries, Camp Fire Girls, and similar organizations make a useful addition and draw the attention of parents to the use that can be made of community resources.

METHOD OF ORGANIZATION.

The organization of an exhibit of this kind may be illustrated by the junior exposition held as part of the Seattle Child-Welfare Exhibit, and accomplished with a minimum of cost.

The first step was the calling of a committee of 20, at a meeting of which the classification of exhibits was settled and a committee of three placed in charge of each department. The departments in the Seattle exhibition were as follows (see Appendix 4 for complete blank):

- Gardening.
- Woodwork.
- Toys.
- Electrical and mechanical apparatus.
- Printing.
- Arts and crafts.

Domestic science.

Domestic art.

Millinery.

Pets.

The departments were further divided into age groups—those under 13 in one group and those between 13 and 16 in another. In an exhibit for parents of young children a special division might be made for children under school age.

Twenty-five thousand printed announcements of the exhibition were sent through the schools, reaching every home. The back of this announcement contained an entry form, which was to be returned by a given date. These forms were assigned as received to the committees responsible for the different departments, which then made requests for space on the basis of the applications received. The hall was then diagrammed and tables were secured and assigned to various committees. Since the space even of an armory proved insufficient to accommodate all demands, large numbers of duplicate exhibits were rejected, the choice being determined partly by order of application and partly by the desire to represent all sections of the city.

At the opening of the exhibition the children came to the hall with their exhibits and were sent to the proper department, where they met the committee in charge. The committee received each exhibit and attached to it an identifying tag, made by taking an ordinary manila tag, writing the child's name on it, and then tearing it in half. The child kept half as his check on the exhibit, and when he returned to claim his article he proved his ownership by fitting the two pieces together. (For a slightly additional cost a somewhat more convenient set of numbered tags could be secured.) Big boys from the schools acted as guards, but many of the children wished to stay through most of the day with their exhibits in order to explain them.

Tables, ropes, ribbons, manila tags, and the preliminary printed announcement containing the entry form were the only items of expense. Prizes have been found to be not only unnecessary in stimulating the willingness of the children to participate, but productive of embarrassment and disturbance. The Seattle committee even decided at the close of their exhibit that a merit badge for all participants would have been better than the blue and red ribbons with their suggestion of competition. The children should feel not that they are competing with each other, but that they are all uniting in a common display of the "work of the boys and girls of the community, showing something of their skill, perseverance, and ingenuity, and how they use their leisure time."

HOME-PLAY EXHIBIT.

An exhibit on home play, showing equipment for a back yard and for indoor play, is a valuable addition to a display of children's interests. A possible list of such equipment is given below; some of it can be made by parents, some by a manual training class in the high school (see illustration No. 2), and some can be borrowed from local Play room.

PLAY IN THE HOUSE—GOOD EQUIPMENT

Play room.
 Cupboard for playthings.
 Pencils.
 Colored crayons.
 Water-color paints.
 Cardboard.
 Colored paints.
 Scissors.
 String.
 Rags.
 Paste.
 Molding wax or clay.
 Dolls.
 Shelves.
 Pebbles.
 Blackboard.
 Pennants, flags.
 A few well-chosen mechanical toys.

PLAY IN THE YARD—GOOD EQUIPMENT.

Sand box (preferably raised on legs, with benches around, to avoid dampness and dirt).
 Low swing.
 Playhouse.
 Indian costume.
 Express wagon.
 Wheelbarrow.
 Ladders to climb (2 ladders, 8 feet high, connected at top with 10-foot horizontal ladder).
 Slide, 6 feet high, 8 feet long.
 Balance beam, 10 feet long, 6 or 8 inches above ground. (See illustration No. 3.)
 Garden patch.
 Set of garden tools.

SUPPLEMENTARY EXHIBITS.

An exhibit of children's interests is capable of indefinite expansion, limited only by time and space, and to a less degree, by money. An organization of Boy Scouts or Camp Fire Girls would have a wealth of material to show on the interests and ideals of older boys and girls. Kindergarten material might be displayed from the standpoint of its use, not in school rooms but in the home. Where the material is expensive, ways should be shown in which the mother can follow the same idea in homemade materials. Mothers who have previously been teachers or kindergartners should be able to prepare exhibits of this type.

The local public library would probably be glad to prepare an exhibit of a child's library, showing books for different ages. A separate exhibit might also be made of educational pursuits which can be introduced to the child as hobbies. Books on insect life, simple electrical equipment, a good microscope, indicate the kind of articles to be included here. The dramatic instinct in children could be shown by a program of chosen performances made up by children. This should, however, be omitted unless groups of children are already giving such performances to their friends.

STATE-WIDE EXHIBIT.

It is quite possible to make an exhibit of children's interests on a State-wide scale through any State organization which has county or district branches. This would involve county displays at county fairs, culminating in a State exhibit, in which each county is assigned definite table space and wall space which it is asked to fill with an exhibit selected for its suggestive value to parents. Elements in determining this value would be the variety of interests shown, their use in the child's development, their applicability to children of varying ages and tastes, and the ease and economy with which the materials can be secured. Local exhibits which can not be shipped, such as playhouses, can be illustrated by photographs; but these should never form a large part of any exhibit. The first exhibit of this kind is planned for Portland, Oreg., in October, 1915, under the State Congress of Mothers.

RECREATION SURVEY.

In communities where the time, money, and workers for a recreation survey are obtainable the results can be displayed to great advantage as the central feature of an exhibit of children's interests.

In case a complete survey seems impossible or inadvisable, some of the investigations commonly used in such surveys can be carried

on by local committees of volunteers and will furnish interesting exhibit material. Among these are:

(a) A study of typical districts on a bright afternoon or Saturday to see what the children are doing, whether they are—

1. Playing in the yard.
2. Playing in the streets.
3. Loafing on the streets.
4. Playing in vacant lots.
5. Playing in playgrounds.
6. Going somewhere.

(b) A study of school children's compositions written on Monday in the sixth, seventh, and eighth grades on "What I did on Saturday and Sunday." The children should be asked to try to put down as many things as they can remember rather than an elaborate account of one event. These activities can be grouped as (1) outdoor play, (2) outdoor loafing, (3) indoor exercise, (4) indoor quiet play, calling, etc., (5) reading, (6) motion pictures, (7) housework, (8) miscellaneous. The number of children doing any of these and the number of times each activity is mentioned form separate studies. Comparisons of boys and girls are interesting. Comparisons of different sections of town often will show the influence of a playground, settlement, or large gymnasium in an interesting way.

(c) Children's compositions on "The kind of motion pictures I like best," or other suitable subject, properly classified and charted.

(d) Children's designs for an ideal yard and garden, preferably conducted through the art department of the schools. In the Toledo Child-Welfare Exhibit a group of selected children made models in sand, gravel, paper, felt, and other materials which they themselves chose to embody their ideas.

(e) A directory of organizations which deal with the interests and ideals of children, the amount of space allowed to each being determined by a committee composed of representatives of all the organizations. Any community work—playgrounds or social centers—should be especially featured.

COMMUNITY CHILD-WELFARE EXHIBITS.¹

The exhibits so far discussed have been chiefly concerned with a direct appeal to parents regarding the health and proper care or the interests and ideals of their children. They have been exhibits such as could be prepared without great expense and without outside direction in any community in which a group of interested people

¹ See bulletins published by the National Child-Welfare Exhibit Association, 30 East Forty-second Street, New York City, the Russell Sage Foundation, 130 East Twenty-second Street, New York City, and the Educational Exhibition Co., Providence, R. I., for detailed description of large exhibitions and consideration of problems raised by them.

willing to give time and work can be assembled. The preceding discussion has shown, however, that the tendency in all such exhibits is to expand to include community problems in health, recreation, and other aspects of child welfare. Unless the problems involved in such expansion and the committee organization necessary to meet them are deliberately faced, the exhibit is in danger of becoming a miscellaneous combination without proportion, touching upon some problems extensively and perhaps one-sidedly and ignoring others that are equally important for the welfare of the child.

While any organization with sufficient medical knowledge may hold an exhibit on the care of babies, and any organization with access to enough children may hold an exhibit on children's interests, a community child-welfare exhibit can not be effectively held without the cooperation of all forces in the community which deal with the welfare of the child. No community is ready for such an exhibit until there is a united conviction among the leading social workers, including those interested in health, education, and recreation as well as in philanthropy, that they have certain definite facts in their possession with which the public should be made acquainted. This does not necessarily imply a complete community survey, but does imply a knowledge of definite conditions, of laws affecting them, and of desired improvements. Without the consciousness of a message based on such knowledge and the cooperation of an effective group in the expression of it an exhibit dealing with community needs is a waste of time.

COMMITTEE ORGANIZATION.

The general committee responsible for such an exhibit should contain representatives of all prominent movements on behalf of the welfare of children and of all large religious and industrial groupings of the community which need to be considered in securing the results advocated by the exhibit. This committee will probably be too large for active work and should choose from its number a smaller subcommittee to handle administrative details.

If the exhibit is a large one, this smaller executive committee will wish to place many details, such as finance, publicity, program, in the hands of special committees. The following is a possible list of such committees, although in a very large city exhibit even these committees may find it necessary to divide their work among subcommittees, as the detail may prove too great to be covered by the groups outlined.

Finance, or ways and means.—This committee is charged with securing gifts of materials as well as of money.

Publicity (see types of publicity mentioned above under the head of "Baby week").—This committee also may have charge of all publi-

cations, such as the handbook of the exhibit and the various leaflets for distribution in the sections, or, if it seems advisable, a literature committee may be created to supervise all educational publications. Even if no funds are allowed for special literature, such a committee often can secure a well-balanced supply by offering suggestions to boards of health and other organizations which have a fund for printing. All exhibitors should submit to this committee copies of any leaflets they wish to distribute, and the approved copies should be kept at the information desk as a check against unauthorized literature. Appeals by exhibitors for money or members usually are not permitted, unless forming an unimportant part of educational pamphlets already printed.

Installation.—This committee is charged with the planning of the floor space, the decorations, the color scheme, and the general appearance of the exhibits. Its work will be outlined later in some detail under those heads. A public-spirited architect makes a good chairman for this committee. Secretaries of the carpenters' and the painters' unions have been found to be useful members, especially in strongly unionized cities, where they have often saved much time and many complications in getting the bids for construction work and materials. Persons who are in a position to secure volunteer service from artists, cartoonists, or decorators are also useful on this committee. One or two advertising men or headline writers may also be of use for consultation by exhibitors regarding effective wording, but so much work of this kind is needed that it will probably be necessary to have for this purpose a paid exhibit expert in the administrative office.

Hospitality and explainers.—This work may be done under one or two committees, as seems desirable. While each exhibitor or exhibiting committee should as far as possible furnish demonstrators or explainers, a supervising committee is needed to supply gaps in special exhibits, to furnish general guides around the exhibit, to manage the information desk, and to see that the public is welcomed and shown the objects of greatest interest. Explainers furnish the living element in an exhibit; they help to stop aimlessly wandering crowds, to focus attention on special points, and to correct mistaken impressions. In some exhibits the hospitality committee has taken charge of the check room, the water supply, the women's rest room, and has greatly assisted in the promotion of cooperation and friendliness by occasional social functions, before and immediately after the exhibit. An informal dinner held a few days before the exhibit opens, to which all committee members, explainers, donors, and people vitally interested are invited to hear five-minute presentations of the work of the committees, is a simple matter to arrange and is usually the scene of real interest and enthusiasm. An informal gath-

ering, held for three-quarters of an hour on closing night, at 10 o'clock, in the main court of the exhibit, with light refreshments and impromptu anecdotes about the week's happenings, proves a pleasant way of relieving the strain of the week's work and welding together the working groups which have been formed by the exhibit.

Program.—The work of this committee will be treated later in more detail. It includes the direct control of all lectures, motion pictures, and general entertainments, with sufficient oversight of all living demonstrations to prevent interfering programs. Its membership should usually include all persons who are directly responsible for any large special performance, such as the supervisors of music and gymnastics in the schools, the playground director, the head of the Boy Scouts, etc.

Exhibiting committees.—In addition to the committees above mentioned, charged with the control of certain aspects of the exhibit, it will be found advisable, in order to avoid duplication, contradictory statements, and lack of proportion, to group the exhibiting organizations and individuals into committees on a few main subjects, each allotted a share of floor space and charged with working out a comprehensive, well-balanced exhibit in its particular field. An exhibit of subjects is much more effective in securing popular support for community measures than an exhibit of organizations; yet when various organizations pay for exhibits their wishes must be considered. A grouping of the type suggested should be the first step in an effort to persuade contributing organizations to subordinate self-advertising to the display of community problems and resources. A simple grouping might comprise committees on these subjects:

Health.

Recreation.

Education.

Social service.

Approximately one-quarter of the floor space should be given to each subject and on each committee should be placed representatives of all the organizations entitled to be considered in planning a community program on that subject.

For a large city a more detailed grouping would be necessary, arranged in accordance with the needs of the community and the plans for the exhibit. The following lists of committees, from the Toledo and Rochester exhibits, need not be followed in detail, but will suggest subjects which should be included:

ROCHESTER EXHIBITING COMMITTEES.

Health.

Homes, including food, clothing, standard of living.

Schools, public and parochial.

Library.
 Settlements and clubs.
 Recreation.
 The child in industry.
 Churches and Sunday schools.
 Law and the child.
 Philanthropy.

TOLEDO EXHIBIT COMMITTEES.

Health:

Care of babies.
 The child's food.
 Child hygiene.
 Children's health conference.
 Toledo health survey.

Schools:

Public.
 Parochial.

Interests and ideals:

Home occupations.
 Home surroundings.
 Boys' and girls' interests.
 Sunday schools.
 Toledo recreation survey.

The working child.

The dependent and delinquent child.

When an exhibit reaches this proportion, however, an executive office with an experienced director in charge becomes no longer an advisability but a necessity, and further details of organization must be worked out in accordance with local conditions.

FLOOR PLANS.

In any exhibit, except a very small one, the problem of the proper arrangement of space is an important one and becomes increasingly complex as the exhibit grows larger. Arrangements for women's rest rooms, baby rest rooms, toilets, dressing rooms for performers in living demonstrations, lecture rooms for stereopticon and motion pictures, administration office, and storage place for apparatus must all be considered in planning the exhibit, even if some of these conveniences are finally decided unnecessary. Aside from these arrangements a careful planning of the exhibit space itself will greatly add to the effectiveness of the whole exhibition and of every division in it. Several points should be considered in a good floor plan.

1. The observer should be able on entering to gain a fairly clear idea of the extent of the whole exhibition and its main divisions.

This is usually accomplished by devoting the center of the hall either to a central court (see Frontispiece) surrounded by columns and railings and reserved for large living demonstrations or to low exhibits, which will not obstruct the view of the entire hall from the entrance. Around this court runs a wide aisle (12 to 20 feet), and beyond, next to the walls, come the various exhibit sections, with a large sign above each, visible from the entrance and as far as possible from all points in the hall.

2. A "one-way exhibit," in which the spectator travels a path which passes all exhibits in a fixed order, is undoubtedly desirable when it can be attained. An exhibit filled with crossing aisles with booths on each side is confusing, but it is not necessary to go to the other extreme and compel observers to travel a definite and intricate path guarded by ropes. A clear exhibit arrangement, such as that described above, with a rope at the entrance to start the crowd in the right direction, will answer the purpose. If an exhibit is held in several connecting rooms, instead of in one main hall, every effort should be made, by signs and arrows, to make the subject matter and the distribution of the entire exhibition clear to the entering visitor.

3. Long walls covered with wall exhibits and facing each other at a distance of less than 16 feet are very ineffective. Consequently it is unwise to divide the exhibit into a large number of narrow booths, each occupied by an organization. It is better to divide it into large sections, under the committee groupings suggested above, and to plan each section with reference to variety of exhibits, including some wall exhibits, some models, and perhaps some living demonstrations. Shallow booths within the section may be needed for living demonstrations or collections of models and materials.

UNIT CONSTRUCTION.

For rapid and efficient work and harmonious appearance a fixed unit of wall space is essential, and variations from it should only be allowed for good cause by the installation committee. The exact size of this unit will depend upon local materials available for wall construction; 3 by 6 feet or 3 by 5 feet is a good size and makes a substantial looking wall, on which all the available space within the range of easy vision is utilized. Many traveling exhibits use much smaller units, such as 22 by 28 inch cardboard. These are convenient for transportation, but are ineffective for large exhibits, as they break the wall surface into too many divisions and interfere with continuity of idea.

Construction of traveling exhibits.—In many large exhibits wall charts are planned with the expectation that they may be used afterwards for traveling purposes. It is therefore worth while to consider in this connection the forms of exhibit construction that lend

themselves to inexpensive transportation, as well as those that are more solid and imposing. Many State departments or State organizations have been deterred from constructing traveling exhibits because of the supposed cost both of initial construction and of transportation. Large sums can no doubt be spent to advantage on State traveling exhibits, as in New York, where the State board of health maintains three complete traveling exhibits on infant welfare, each in charge of an exhibit manager, a nurse, and a mechanic, and each covering 70 linear feet of wall space and containing, in addition, the complete equipment of an infant-welfare station. But States, and even counties, have prepared exhibits which cost little to construct and which are easily transported. The State Board of Health of Maine uses photographs and inscriptions on 11 by 14 inch cards mounted on long strips of burlap. The county health officer of Clinton County, Ind., constructs very inexpensive exhibits on 14 by 22 inch cards, with the lettering stamped by a clerk in his office. In installing this exhibit, strips of burlap 3 by 6 feet in size are hung on the walls to cover irregularities of background, and the cards are fastened to this by small clamps with pin attachment. These exhibits are circulated through the rural schools, each school being supplied with a strip of burlap, on which the exhibit is changed from week to week.

For some purposes a better variation of this plan is to hang cards one above the other with a narrower card at the top for the title. (See illustration No. 14.) The measurements here selected for the larger cards (17 by 28 inches) make the entire panel about 58 inches high (thus covering all available wall space within easy reach of the eye), and give a fairly large unit for a single subject. The 5-inch boards will accommodate a 3-inch title; the 17-inch boards are well suited to one or two photographs each, with appropriate inscriptions. The measurements of larger cards should be determined with reference to parcel-post requirements.

This panel can be hung either on the stationary framed screens or wall units of more expensive exhibits, or on burlap walls, or even suspended from wires or ropes attached to poles. Cardboard of this size can easily be obtained in any tint. If extreme economy is desired, "chip board," a card of finish similar to manila paper, is even cheaper than white cardboard. It is, however, rather too absorbent for fine ink work.

Two sheets of corrugated strawboard, pasted together with the corrugations running in opposite directions, makes a somewhat more substantial background, but one which is light and inexpensive, and to which papers and photographs can be pasted without warping. Pieces of tape glued between the sheets are used to hang one background from another. To send this exhibit by parcel post, smaller

units are required, as the thickness of the strawboard materially increases the bulk of the package. The North Carolina State Board of Health uses a wall panel composed of three 12 by 18 inch boards of this type. Its total height, about 38 inches, is well adapted for use against school blackboards. This board also plans supplementary work in connection with the use of these exhibits, such as essays from the children on what they have learned, or on conditions in the school grounds which conform or do not conform to the sanitary conditions outlined in the exhibit.

Another cheap and durable form of traveling exhibit, used by the Iowa State University, can be made on holland cloth (window shades), held taut by light rollers at top and bottom. Each roller is split lengthwise into halves (the method used in mounting maps), and the cloth is fastened between them. The panel is hung from the wall by small rings, through which pass loops of tape the ends of which are secured between the split halves of the top roller.

The cloth furnishes a large surface for lettering, drawing, or painting, but can not be used satisfactorily for photographs, which are damaged by rolling. The photographs can be mounted separately on cardboard and numbered to correspond to spaces on the shade, to which they can be attached later by paper fasteners.

More permanent construction.—Undoubtedly the larger framed panels (size about 3 by 5 feet), made of Upson board, beaver board, or some of the many varieties of building board, surrounded by a wooden frame, are both more imposing and more durable. The exact type of wall board to be secured will depend upon local supply houses. In general, boards with a porous surface should be avoided, as they increase the cost of painting and pasting. When panels are to be shown for a long time in one place, and when they contain expensive photographs, cartoons, and lettering, the extra cost of the heavier background (about \$1 to \$1.50 per panel, including frame) is well worth incurring.

Many States and national organizations have found this type of exhibit background worth while, even for traveling exhibits, in spite of the much heavier cost of transportation. The State departments of health of New York and of Indiana have different styles in exhibits of this heavier variety, especially designed for compact packing, durability, and speed in installation and planned for setting up without attachments either to floor or wall.

The method used by the New York State traveling exhibit, in which the walls are formed by the panels set up on detachable legs, is well worth considering, even for large permanent exhibits occurring only once. It may be supplemented, perhaps, by a cheaper type of construction along the main walls of the building or in burlap booths

designed for models or living demonstrations. Some installation committees will find it cheaper and easier to construct a scaffolding with ledges on both sides about 30 inches from the ground. The panels rest on these ledges and are fastened by means of screw eyes in the upper frame of the panel attached to nails driven in the top beam of the scaffolding.

Whatever type of wall construction is used, two facts should be borne in mind: First, that ease in handling and arrangement demands that on many occasions the wall panels must be stacked upon each other, and that therefore hooks or other projections let into the back of the frames are objectionable; second, that immediately before and during the exhibit many rearrangements of panels will take place, due to discoveries regarding lighting, movements of crowds, or committee preferences, and that consequently the panels should be fastened to the scaffolding in such a way that they can be easily transferred from one position to another by unskilled laborers or committee members. The plan mentioned above, whereby the framed panels rest on a ledge and are fastened by nails driven through screw eyes inserted in the top of the frame, safeguards both these points, especially if the screw eyes are all placed in the same relative positions on the frames, so that nails once driven will be available for any panel. Unless the lower ledge is wide, it may need a raised piece on the outer edge.

COLOR SCHEME.

For the sake of harmony it is well for some central authority, probably the installation committee, with the approval of the executive committee, to fix a uniform color scheme and allow variations only for good cause. Soft grays have been more used than any other color. Soft, dull greens and blues are also good. Sometimes the lettering is done directly on this background—a method which produces a harmonious appearance, but in which it is difficult to make the slight changes demanded in most exhibits. Another plan is to do the lettering on cards or heavy paper, tacking or preferably pasting this to the background, in well-planned designs. (See illustrations 4 to 9, inclusive.) This method makes readjustments possible at the last moment before the pasting is done, and is frequently less expensive, as the lettering on cards is more easily handled. On the other hand, paper is injured by water and can not be cleaned as easily as oil paint. The exhibit of the Children's Bureau in the Panama-Pacific Exposition used a natural color (cream) Upson board, with a gray frame and with gray papers lettered in black and white.

CONTROL BY EXECUTIVE OFFICE.

The extent to which details can be controlled by the executive office will depend upon the paid force available. The central committee should at least prescribe the division of space, size of wall unit, general color scheme, and should arrange for the joint purchase of all construction materials. Large signs and signs above a certain height must be limited by the central committee, which should also send out advice regarding styles of lettering, photographs, etc. The effectiveness of the exhibit will be increased materially if all the lettering and mounting can be handled through the central office. This, however, necessitates the employment of an exhibit expert¹ to consult with the committees, make suggestions on arrangement and wording, cut down long, verbose statements, which are both ineffective and expensive, and handle all arrangements for lettering, enlarging of photographs, etc. In many large exhibits the expert has collected the material and planned the panels with little consultation of local committees. This plan usually means a clear-cut, attractive presentation of the subject matter, but sacrifices the local discussion and the working out of a statement satisfactory to all concerned, upon which the final results of an exhibit largely depend. A compromise between these two extremes demands tact and effort, but for the best results in any community both elements are needed—a careful working out, by the best forces in the community, of the exact program for which they wish public cooperation; and a clear, concise, attractive, and striking statement of that program in exhibit form under expert guidance.

SUGGESTIONS FOR EXHIBITORS.

The chief essential of a successful exhibit is variety. No matter how small the exhibit, the various ways in which facts may be presented are worth careful consideration. An exhibitor or exhibiting committee should first ask, "What, expressed in the simplest, clearest, briefest manner, is the exact message I wish to give the public?" When the answer to this question is clearly formulated the best method of presentation should be considered. How much can be shown by a living demonstration, such as a dental clinic or food preparation? What can be shown by electrical devices or models, either illustrative models, which are copies of existing objects, such as a baby's stomach, a good dairy, a school garden, or a children's

¹ On the basis of past exhibitions, at least one person should be employed in the executive office for eight weeks for every \$1,000 to \$1,500 to be expended from the central fund. Even smaller exhibits will benefit by a week's consultation with an expert. Child-welfare exhibits of sufficient size and importance to stir cities from 100,000 to 400,000 have been held at a cost of \$3,000 to \$8,000, including at least one paid expert and local office assistance. The contribution of much time and material and many exhibits is usually necessary in addition to this central fund.

institution, or diagrammatic and symbolic models used to present abstract facts in graphic form, such as pasteboard cubes to represent the different expenditures of the city departments, or the "one in seven" model, in which every seventh baby is replaced by a coffin, to show the death rate? What facts can be shown only by photographs, cartoons, charts, and statements? Each of these main types of exhibit method—wall exhibits, models, and living demonstrations—will be considered separately.

WALL EXHIBITS.

Under this head are comprised all flat exhibits, such as printed signs, charts, diagrams, and illustrations. This exhibit material is the least striking of all, and yet a small amount of it is always necessary. The best living demonstration or model needs explanatory signs, and many facts can be presented only by graphic charts or statements. Precisely because of the difficulties in making this type of material effective, special care is needed, and if possible the advice of an exhibit or advertising expert, to make the wall exhibits striking and varied.

The size of the wall unit has already been discussed. This unit should be treated by the exhibitor not as a background for a miscellaneous collection of photographs and aphorisms, but as a single illustrated statement on one subject. Wording and grouping of photographs should be carefully planned, so that the most important matters stand out most clearly and the rest of the material is properly related. Probably no part of exhibit technique is as difficult as this, but the time spent is well worth while if the exhibit is to give a true impression. Friends totally ignorant of the subject matter should be consulted in order to see what impression the exhibit will produce on the casual visitor.¹

Special care must be taken with statistical charts in order that they may be accurate, clear, interesting, and not misleading.² If maps are used, an outline map, on which a few things are filled in with color or strong shading, is much better than the usual city or State map, which is full of irrelevant detail. A common error on maps and diagrams is to use different colors to designate various degrees of the same condition, such as the infant death rate. Different shadings of the same color, or of black and white, are far less confusing wherever differences of degree but not of kind are to be shown. Colors may, however, be quite arbitrarily chosen to represent

¹ See *Twelve Good Screens and Why They Are Good*, National Child-Welfare Exhibit Association, 30 East Forty-second Street, New York City.

² This subject has been exhaustively treated in *Graphic Methods for Presenting Facts*, 372 pp. Willard C. Brinton, Engineering Magazine Co., New York City.

different kinds of things, as different trades, different causes of death, or different city departments.

Lettering.—Plain, upright letters, varying from three-fourths inch in height—or even smaller for footnotes, etc.—to 2 or 3 inches for special display, are the best. The sloping italics, favored by sign writers for reasons of speed, are especially hard to read; and, contrary to the general opinion, red letters, especially the cheap orange red used by many sign painters, which produces a glare of red and green shadows and obscures the lettering, are not effective. A color variation for important words or to lend variety, however, is desirable when used in moderation. Some gray backgrounds will take both white and black letters. Light backgrounds will take black and some other good color.

Pasted or stamped letters will prove less expensive than sign lettering if careful volunteers can be found to use them. Paper letters in different colors and sizes with gummed backs are obtainable. In using these the signs should be designed by a person with a sense of artistic balance and then pasted or stamped with great care. One designer can keep several pasters busy. If any of the workers are paid, the final cost will be little, if any, cheaper than sign lettering; but the method is useful for committees of volunteers or in towns where good sign lettering is hard to secure. Pasted letters are clearer and more effective than stamped letters, but they are more expensive and tend to peel off if used in traveling exhibits. Stamped letters will rub unless the very best grade of ink, made especially for stamping, is used. With both these forms of lettering variety in size and style of type should be introduced.

Photographs and illustrations.—One large photograph showing significant detail is worth several small ones chosen in an attempt to give an exhaustive presentation. Photographs 11 by 14 inches in size, or even larger, are desirable; smaller photographs are allowable where there is little detail. A flat finish is best, as it does not reflect light and will take paint if it is desired to color any of the photographs. Abstract ideas can frequently be presented by cartoons (see illustration No. 4), which are expensive to buy but may often be contributed.

Many attractive variations can be introduced in the use of illustrative material. The activities of a vacation school in Toledo, of which no photographs had been taken, were shown by children's paper cuttings made from memory and showing what they had done the previous summer. These were attractively mounted and used exactly as photographs would have been. In pedigree charts, used to show the results of a bad inheritance, figures cut from magazines and fashion books can be used in place of the uninteresting dots, each

figure being tinted to represent the idea conveyed and surrounded by a circle of appropriate color.

Devices which call forth the activity of the spectator are especially good. Thus a revolving wheel set in a wall panel and appropriately lettered may be used to illustrate an endless sequence, such as "Child Labor, Unskilled Labor, Low Wages, Poverty, Child Labor," or "Parenthood, Infancy, Childhood, Youth, Parenthood." The wheel may be partly hidden so that the spectator has to turn it to find out what comes next, while inscriptions above and below the wheel indicate in the first instance the viciousness of the circle and the need for breaking it at some point and in the second instance the fact that good health at any stage is a requisite for good health throughout the sequence. In the exhibit of the United States Public Health Service is a simple but clever device bearing the legend: "Turn this valve till the hand points to the name of your State; the man on the tower will then point to your State's typhoid death rate." Many community child-welfare exhibits have near the exit a placard with the question, "Who is to blame for the conditions here shown?" and the string which the spectator is directed to pull "to find out" discloses a mirror in which he views himself. Mouth hygiene exhibits sometimes use a small mirror set in a widely smiling mouth, with directions to "look at your teeth."

Silhouettes add variety to wall exhibits and were used with good effect in the New York City building in the Panama-Pacific Exposition. Diagrams and figures were painted on cardboard or thin three-ply wood, then cut out and placed in position on the wall panel. A very effective silhouette was used by the fire department to illustrate the different heights to which water is sent by varying pressures. The tall skyscraper, the fire engine, and three different jets of water were all cut from a three-ply wood surface and raised 3 inches from a background which showed the distant clouds. In the 3-inch space thus formed was inserted a thin, red electric-light bulb, which flashed and faded, sending a fiery glow over the clouds and around the edges of the building. Simpler silhouettes may be made of paper in different colors. A photograph can often be made more effective by cutting out all the background and letting the central figures stand in relief as in a silhouette.

Transparencies.—Transparencies may be used either separately or as part of a wall design into which they are fitted; but good transparencies are often spoiled by poor lighting. The most effective lighting in the Panama-Pacific Exposition was that of the United States Forest Service, which utilized the space in front of large windows, framing the transparencies in a continuous black screen which shut out all light for a height of 10 feet except that coming through the transparencies. Where natural lighting can not be ob-

tained the transparencies should be placed on a dimly lighted wall, as the strongest electric light will not compete with direct daylight. If this rule is followed excessively strong lights, which tend to make a glare in spots, will not be needed; a box with a white painted inner surface on which a light is indirectly thrown will be sufficient. Transparencies can be effectively used in unexpected places, set into a large tree stump or an imitation bale of cotton. A peculiarly beautiful effect can be obtained with landscapes by placing lights of different colors behind them, one flashing on as the other fades. The spectator spends some time deciding whether there is a real change of scene.

THREE-DIMENSION EXHIBITS.

Under this head come all exhibits which occupy floor space or table space, including collections of materials and objects, models of various kinds, and electrical devices. Most of the exhibits mentioned under the head of infant-welfare exhibits and exhibits on children's interests are collections of materials, such as baby clothes, foodstuffs, and toys made by children. These are effective exhibits, usually calling forth much local interest and cooperation, and most of the materials can be borrowed for short-time local exhibits. Other exhibits of this type are:

The homes of Mrs. Do Care and Mrs. Don't Care. This shows both a good and bad kitchen and bedroom. The material for the good rooms is borrowed from the stores or the homes of the committee; that for the bad rooms from the local relief societies or the attics of committee members.

A hospital room for a child showing all equipment. Used to present the need for more hospital accommodations.

Equipment for a dental clinic. This may or may not be used as the background for a living exhibit consisting of a free dental examination for children.

A child's library, perhaps shown as part of a small children's room in the public library, with an attendant who allows children to read the books.

Models.—Scale models, or models which are reproductions made to scale of existing or proposed structures, are very expensive and usually unnecessary in a child-welfare exhibit. Illustrative models in which exact dimensions are not followed, but an effort is made to make a graphic presentation of an idea, may often be constructed by manual training classes or kindergartens. The old Moravian "putz," which still survives in the Christmas celebrations of some families, is a model of this type and can be made by any clever boy. It will be useful for Sunday-school exhibits, and a detailed description of its primitive but effective construction may furnish sugges-

tions for other models. A large rough table (4 by 6 feet) set in a corner is used as the foundation on which, by the use of excelsior, covered with moss and fir branches, a representation of a hilly landscape is constructed. Footpaths and a distant desert, across which the wise men are seen coming, are made of sand and gravel. A lake is made with a large tin pan lined with stones and overhung with moss to conceal the edges. Figures are found by diligent search through toyshops and 5 and 10 cent stores. A cave-like stable is made of a packing box about a foot square, with a large entrance cut at one end, through which the figures in the stable are visible; the lines of the box are covered with moss and hidden by trees. Among the highest fir boughs is half concealed a star, cut from tissue paper and set in cardboard, covering an electric bulb which can be turned on from a near-by switch. A model of this type is necessarily frail and must be constructed in position, but it will last for a week's exhibit. Much more durable models have been made by school classes by the use of various materials, such as wood, cement, clay, plasticine, or pasteboard. A good flooring for a model which is to show an open yard is made of rough boards set several inches apart and covered with a fine-meshed wire netting, over which is poured thin cement. The wire provides an elastic foundation which keeps the cement from cracking. The cement may represent paths or grounds around whatever building is to be shown. Grass is made by dyed sawdust dropped on with glue or by roughened felt glued to the cement. The building on such a foundation may be made of thin wood or of cardboard with windows and doors painted in. Smaller models may be made of clay built up on a wooden board. Streams and rivers are then painted directly on the board.

Among the models which have been prepared for child-welfare exhibits by volunteer work are:

A good and a bad dairy. This model was made chiefly of wood and cement, with cows from a toyshop and milk pails manufactured out of old tin cans. (See illustration No. 10.) Obviously not all the features of a dairy could be reproduced, but the main idea of care and cleanliness versus dirt and carelessness was effectively carried out. Rotted fence boards were eagerly hunted by the boys for use in the bad barn, and the ingenuity displayed in collecting materials showed a vivid interest on the part of all the class.

Model showing the spread of typhoid, made by the Pasadena High School girls' class in sanitation. This was a landscape made of clay on a wooden floor, with streams painted blue, and tiny houses bought at a toy store. An inscription showed that the typhoid started at house A near a stream; that the discharges from the patient were thrown into the stream; and that in a little village shown farther down the stream half the houses had typhoid. These

were the houses that drew water from the stream. The remaining houses, situated between house A and the rest of the village, did not contain any cases of typhoid, although they were nearer the source of infection. They drew their water from an uninfected well (shown in the foreground) by a test tube which pierced the floor of the model and was seen against painted strata of sand below.

Model showing school playgrounds. This was a contrast model showing how the grounds around one school allowed plenty of space per child, while the grounds around another school were so small that all the children could not find standing room. The grounds were made of cement, sand, and sawdust, as described above, the buildings and railings of wood, while the children were represented by penny dolls. These dolls fixed the scale on which the entire model was constructed, so that their positions in the school yard gave an accurate picture of the open or crowded condition of the grounds.

Beans of different colors are often used to represent percentages. For instance, the number of deaths among every 100 babies during the first year has been shown by black beans mixed in a jar of white ones. This is in some ways a dangerous device, as an incomplete mixing may give a wrong impression which should always be guarded against by an explanatory sign giving the exact figures. In addition to this safeguard, it may prove better to arrange the beans in a very thin bottle, or in a shallow dish, where they can all be seen at once. In the Seattle child-welfare exhibit, beans of different colors in a large shallow box were effectively used to show the numbers of people of different nationalities in the city. A placard above the box gave the exact numbers, but could not have given as graphic a presentation of the mixed character of the city's population as was given by the bean table. A similar use may be made of other objects than beans to illustrate figures which would otherwise have to be shown by a wall chart. Thus, the amounts per capita spent by different cities for health, or recreation, or education, can be shown by little heaps of coin, inside a glass case; this seldom fails to arouse interest.

A clever combination of photograph and model, which attracted attention because of its unusualness, was shown in the New York City building at the Panama-Pacific Exposition. An upright board about 2 feet high ran along the rear of the table, and on it was mounted a large photograph showing the sky line of New York, beginning at the water's edge. On the surface of the table was pasted a photograph giving a much foreshortened view of a surface of water; this appeared to be continuous with the rear picture, and represented the Hudson River. A model of a municipal recreation pier, made of painted wood, was placed directly on the table.

The contrast between two styles of presentation, usually kept separate, that of the photographer and that of the model maker, made the exhibit effective and attracted notice. A similar combination of the method of the model and that of the chart can be made by placing a map flat on a table and using colored upright poles in place of the bar diagrams which would be used on a wall. In many cases the effect thus produced is truer to actual conditions, as when graduated poles, placed in a map of New York City, are used to illustrate heights of buildings in different sections of town. Varying death rates in different parts of town can also be studied better in a model of this kind than in a diagram, as the relative position of various areas can be discerned at a glance.

Moving models and electrical devices.—There are many moving models and electrical devices which, while expensive for the small-town exhibit, are well worth the consideration of any organization planning a traveling exhibit. One of these is the automatic stereopticon, of which there are several types, all operating in daylight.

Typical models are:

The Fly's Air Line, used by boards of health and showing a swarm of flies traveling from stable manure to an open privy and then to the family table.

Part-time Schools, a model owned by the Massachusetts State Department of Education, showing two sets of children changing places in a school and a factory as a band of light passes from week to week of a calendar.

The Path of Life, owned by the New York State Department of Health, showing a series of moving belts upon which dolls, representing people of different ages, move from birth to death according to the ratio shown by mortality tables.

The waste of preventable disease, shown by a model owned by the Public Health Service, in which a long ribbon covered with coins passes continuously out of the pocket of a tall Uncle Sam into the mouth of a crocodile appropriately labeled.

Models of this kind should be prepared by experienced model makers; those made by amateurs are usually unsatisfactory. There are, however, a few simple electrical devices, by the use of which local electricians, and in some cases local committee members, can add effectiveness to an exhibit. Frequently a theatrical electrician can be secured who is especially skilled in work of this type.

The skedoodle plug is an inexpensive attachment (about 50 cents, ordered through any electrical supply house) which can be attached to an electric-light socket and adjusted so that the light will go on and off at fairly regular intervals. The uses of this plug are many. It may be timed for a 10-second interval, and hidden behind a glass or tissue paper star bearing the inscription: "Every time this star

fades, somewhere in Europe or the United States a baby under 1 year dies; 1 every 10 seconds, 6 every minute, 360 every hour. Half of these deaths are preventable." The figures in the inscription are quite necessary to correct the occasional moments when the star will be out of order. A skedoodle plug may also be used instead of a stationary light behind a transparency. It may be used behind a combination of ground glass and paper arranged in such a way that part of an inscription will be visible at all times and part only when the light comes on. Questions and answers, maps across the face of which some comment is written concerning laws or conditions, are types of this use. Careful testing is necessary to secure materials which will be opaque to light and yet will not show through the ground glass when the light is off. White letters of heavy opaque paper pasted upon a background of translucent white paper may be used. A skeedoodle plug may also be used inside an opaque "soothing-sirup" bottle, bearing on a thin, translucent label the inscription: "Dr. Killen's Soothing Sirup Quiets Babies." When the light inside the bottle comes on it makes visible the word "Poison!" cut from black opaque paper. To get the best results the first inscription should be painted in light transparent colors, so that it fades out completely.

Flashers are devices by which one circuit of electric lights can be exchanged for another. The larger type with a sequence of several circuits is operated by motor and is rather expensive, but a single alternation of lights can be made by simple flashers (about \$1 at an electrical supply house) operated by heat contact. Many uses can be made of a flasher of this kind in illuminating first one inscription, then another. The most effective use is perhaps the well-known "illusion" in which one picture or model is mysteriously replaced by another. This can be used to change a bad room into a good one, or to show a dirty beggar at a drinking fountain followed by a mother and child. In a library exhibit an illusion was used to illustrate the statement, "The child sees—right through the pages of the book—the world of which he reads." In this case the book page faded out and disclosed a scene or a globe. Illustration No. 15 shows the construction of an "illusion."

Simple motors with appropriate gears attached can be used to run revolving or oscillating signs and turntables bearing models. A moving panorama made for the exhibit of the Children's Bureau at the Panama-Pacific Exposition was entitled "Our Thirty Million Children," and consisted of a chart showing for successive ages the proportion of children dying, going to school, or at work. A narrow, continuous ribbon bearing a motto sometimes is made to run around the top of a booth. A motor may be made to operate a turntable, not

continuously but by definitely timed movements, so that an inscription or a picture appears for a given length of time and then passes quickly out of sight, to be succeeded by another. This is done by causing a wheel to revolve on which a projection strikes another projection on the revolving sign. The effect is particularly good if the turntable bearing the four or five sided frame containing signs or pictures is hidden in a case of which only one side is open, so that only one sign can be seen at a time. In all experimenting with motors the very best electrical skill is needed; it is not cheap work, except for organizations which have an electrician at their command.

Two or three other specific uses of electrical devices may be mentioned.

"A Day in Baby's Life" may be illustrated by a large clock (first used at the Pittsburgh Baby Week) around which the hands travel rapidly. As they pass different hours they form contacts which illuminate different inscriptions or pictures illustrating the activities of the baby at prescribed hours, such as nursing at regular intervals, being dressed and bathed, and sleeping.

"What to Do" is the title of a large electric wall chart used in the philanthropy section of several child-welfare exhibits. The spectator is instructed to "press the button to find out" where to go "if you want to adopt a baby," "if you know a case of cruelty to children," "if a poor family applies to you for aid," etc. Opposite each question is a push button which is connected with an electric light behind a transparency, on which is inscribed the name of the organization to be consulted.

Magic mirrors, often used for commercial advertising, can be adapted for use in educational exhibits. A clear-cut picture, design, or inscription, made on translucent or transparent material such as paper, celluloid, or ground glass, is placed directly behind a "double mirror" made of two pieces of glass with thin "silvering" between them. The mirror, with the inscription behind it, is then fastened into the front of a shallow box containing lights. When the light is off the darkness of the box, reenforcing the thin silvering, makes a good mirror; as soon as the light is turned on, the hidden inscription or design appears upon the mirror's face. This device can be used with a skedoodle plug if only a single design is to be shown. More complicated mirrors show different signs, one after the other, on different portions of their face and involve the use of a flasher and opaque partitions between the various lights.

Occasionally exhibits occur in which a moving model can be effectively and simply made without the use of electricity or any complicated mechanism. A good example of this is a model used by the United States Forest Service to illustrate the value of forests

in preventing erosion of soil. At the two rear corners of a model about 6 feet square light showers of water fall from faucets. On one side the water is received by a fir forest; it trickles through the branches and emerges as a clear stream flowing through a clear lake into a drainpipe at the front of the model. On the other side the water strikes a bare hillside and is speedily converted into a muddy stream which wears away the hill, converts a lake into an overflowing marsh, and spoils the surrounding landscape. On both sides of the model the water actually completes these operations without interference, and thus gives an effective object lesson.

LIVING EXHIBITS.

A short investigating tour taken on five separate occasions through four of the exhibit palaces of the Panama-Pacific Exposition showed that of 25 exhibits attracting the attention of more than 10 persons all but one depended for their interest upon the constant activity of human beings. A flour exhibit, in which women dressed in national costumes made the breads of various nations; a cigar exhibit, in which girls manufactured cigars; exhibits in which girls gave away food samples; a telephone exhibit, with a man talking to New York; a five-scene illusion, showing the progress of typewriting; a woman who revolved, apparently in mid-air, with her feet executing dance steps above her head; these were the features on which the successful commercial exhibitors relied to draw crowds. Among the educational exhibits the Children's Bureau grouped its exhibits around a children's health conference, with an examination of children, and also carried on demonstrations of home play and the preparation of food; the Bureau of Mines conducted a mimic mine explosion daily, and administered first aid; the Race-Betterment Exhibit supplied free vibrating chairs, in which the tired public, comfortably reclining, unconsciously became volunteer demonstrators.

Other things being equal, the interest taken by any city in a child-welfare exhibit is probably in direct ratio to the number of volunteer attendants and performers. The human element in an exhibit may be of three kinds:

Explainers and guides.

Expert demonstrators and lecturers.

Performers in entertainments and living exhibits.

Explainers.—The organization of explainers has been mentioned under the head of committee organization. That an exhibit "explains itself" to the exhibitor is no reason for dispensing with explainers. As hostesses and demonstrators they draw the public into the exhibit and help to drive home important points. A spectator remembers the things which he discusses. Realization of this fact led, in the Springfield exhibit, to the reserving of a space near the

exit, where discussion concerning both the exhibit as a whole and any questions raised by it was constantly carried on under expert guidance.

These explainers are in some ways more important than the exhibits themselves; a poor exhibit with a good explainer will draw more attention and make a more lasting impression than a good exhibit with a poor explainer. But vivacity and an ability to talk are not the only qualifications necessary. Much harm can be done by inaccurate explaining, and this should be carefully guarded against.

In order to insure competent explainers, each exhibiting committee should as far as possible provide its own, and when this is impossible should apply to the committee on explainers for volunteers, for whose training the exhibiting committee then becomes responsible. Weekly meetings of explainers to receive instruction have sometimes been held to meet this situation. In addition to these trained explainers, there is always room for general guides and hostesses in attendance at the information desk and free to be assigned wherever needed. All explainers and demonstrators of every kind should report to the information desk on entering the building, so that they may be easily reached and so that the chairman of explainers may be sure that the entire floor is well provided with them.

Demonstrations.—These range from the simple demonstration, which is hardly more than an explanation of the exhibit, to changing programs held on special stages distributed throughout the exhibit. They are directly under the control of the several exhibiting committees, which should keep in close touch with the program committee to avoid conflict with programs near by. Some demonstrations are practically continuous; others are reserved for special hours or special days. The committee on health, for instance, may wish to have a nurse giving a continuous demonstration (on a doll) of the bathing and dressing of the baby. Demonstrations on the proper preparation of food for young children are more apt to be a part of a set program, varying from hour to hour and day to day as different foods are shown. A dental examination room, an infant-welfare station, or a complete children's health conference may be living exhibits in the health section. (See illustration No. 11.) In the Rochester Child-Welfare Exhibit a small booth was set aside for the inauguration of the spring fly campaign, for which children enlisted and received souvenir pledge cards and medals; the crowd attracted here was very large. (See illustration No. 12.)

A committee on schools frequently finds it advisable to carry on small demonstration classes to illustrate some of the subjects taught in the schools, such as manual training, domestic science, drawing, or paper cutting. A recreation committee often centers its display

around a small playground, which cares for the children who wish to come. The library may offer a similar attraction to children by maintaining a small children's room in actual operation. (See illustration No. 13.) The philanthropy committee (or the health committee) may manage a small day nursery for the benefit of mothers who wish to see the exhibit. In all these cases the children themselves, merely by availing themselves of opportunities offered, make a living demonstration to the public of the worth of these opportunities.

In some parts of the exhibition, notably those devoted to settlements, clubs, and associations, it may seem wise to erect a special stage or set aside a special floor space for the joint use of several organizations, no one of which can furnish enough material to fill it. Boy Scouts showing their "first aid to the injured," Camp Fire Girls' activities, classes in weaving or pottery from a settlement, demonstrations of folk dancing not suited to a larger space, a class in butter making from an industrial school, or a class in speaking from an institution for the deaf are all among the possibilities in a space of this kind.

Under this head of living demonstrations would come also special conferences for mothers, held under the health committee and conducted by local doctors, and specially conducted tours through various sections, for which some well known local person is announced as guide. These demonstrations can well be carried on under the exhibiting committees, but if they promise to attain much size and importance the program committee should be consulted about them.

Program committee.—Before selecting a program committee the executive committee should first of all decide on the general type of program desired. Large conferences with out-of-town speakers have almost invariably proved disappointing when held in connection with an exhibit, unless the exhibit is a very small one, chosen simply to illustrate the conference. Custom probably demands an exception to this rule in the case of a formal opening, where the speeches should be short, pointed, and interspersed with music or other forms of entertainment. One or two small conferences or round tables of workers may be valuable if the audience is chosen as carefully as the speaker and the subjects restricted to matters of immediate importance on which action is pressing. But most of the social workers of the community should be engaged at this time in explaining the exhibit or planning the follow-up work to come after the exhibit. Any conference which diverts them from these duties is likely to do harm. If sufficient money is available for good speakers, it is a much better plan to bring them at intervals after the exhibit is over, when each address can be separately advertised and when the exhibit

material reenforcing the address can be assembled again and set around the lecture hall. Such addresses, as well as the round tables above mentioned, may be referred to the program committee, or it may be decided that they can be handled better through the committees interested in the subjects to be represented.

After disposing of the question of conferences and referring the minor demonstrations in the sections to the various exhibiting committees the main question remaining concerns the kind of program of entertainments to be planned for the central court or main stage of the exhibit. Opinions are divided concerning the value of large, general entertainments occurring twice daily and drawing great crowds of people only partially or not at all interested in the subject matter of the exhibit. As a rule, however, demonstrations on a big scale of activities of the community's children, such as choruses of 1,000 voices from the schools, folk dancing, and gymnastics from the schools and playgrounds, and similar displays, have a very important function. They serve as exhibits of community activities; they give large numbers of children and their parents a feeling that they have a share in the exhibit; and they draw out not merely a crowd, but a thoroughly democratic crowd, a crowd coming to see its children perform, not yet interested perhaps in all the matters displayed in the exhibit, but the crowd, none the less, upon which the securing and enforcing of all remedial legislation will depend. If the large performances in the central court or on the main stage are restricted to three-quarters of an hour in length, and if the explaining force is well organized and ready to handle the crowds that are released immediately after the entertainments, no harm but rather good would result from a type of demonstration which brings out thousands of people. To safeguard the children taking part the entertainments should be in the nature of an exhibit of work actually carried on in schools, playgrounds, or under volunteer agencies, with a minimum of rehearsal and consequently with the possibility of using different children for almost every performance. This arrangement is also advisable in order to draw parents from as many parts of the city as possible.

If a program of this type is agreed upon by the executive committee, then the program committee should be made up of the persons who are fitted to take charge of separate programs, such as the supervisors of music and gymnastics in the schools, the physical director of the Young Men's Christian Association, leaders of the Boy Scouts and Camp Fire Girls, etc., under the chairmanship of some person mutually acceptable. This committee need meet only twice—once to assign the times of the performances and decide upon the equipment which is needed jointly, such as piano and dressing rooms, and later to determine details of floor management. The installation committee

must be consulted on many of these matters, and careful consideration must be given to questions of special equipment, such as chairs needed for some performances but not for others. The frequent movement of large numbers of chairs, for instance, may prove a serious item of expense and should be carefully guarded against.

Special pageants and dramas written for performance by children at child-welfare exhibits are frequently well worth giving. A pageant on a large scale, lasting for an entire evening, is perhaps on the whole inadvisable, as it interferes seriously with the conduct of the rest of the exhibit and can not be given with the best effect under exhibition conditions. Two short plays, prepared on subjects concerned with the welfare of children, were used to great advantage in the Pittsburgh Baby Week. One of these, entitled "The Theft of Thistledown," will serve as an example. It depicts a fairy court, to which, amid dances and fairy revels, Thistledown brings an earth baby stolen from conditions which she graphically describes. In punishment for her theft she is condemned, greatly to her dismay, to become herself that much loved and much abused thing, an earth baby, until such time as mothers learn to treat their babies properly. The play closes with a picturesque appeal to the audience to help free poor Thistledown.

AFTER THE EXHIBIT.

Some possible results to which exhibits may lead have been mentioned in connection with the infant-welfare exhibits and health conferences designed to encourage the establishment of infant-welfare stations or child-welfare centers. The results of a community child-welfare exhibit are more varied, depending upon the particular needs emphasized by the exhibit and the particular organizations that were especially active in working for results. An exhibit is a form of education through publicity. If considered an end in itself, the closing night will indeed be "the end"; if used as a tool, it may be made the means of real accomplishment. A new factory inspector in Kansas City, a housing inspector in Louisville, a \$25,000 school building in a congested district of Northampton, increased sewer connections in Easthampton where the ice supply of the town was menaced are types of results which have been secured in practically every community that has devoted sufficient time and thought to the planning of a child-welfare exhibit. In cities where no organized combination of social agencies exists to interpret and carry out the legislative program suggested by an exhibit, the exhibit organization itself is often a first step to such a combination and leaves behind it committees which are natural working divisions of the social forces of the community, together with lists of many new work-

ers discovered by the committee on explainers. Where no distinct need exists for a new grouping of the city's forces the child-welfare exhibit should practically disband after the exhibit instead of adding to the numerous agencies already existing and should turn its work and its possessions over to the agency best qualified to carry on the work not yet finished.

Local exhibits prepared for a large exhibition may be used again and again in neighborhood exhibits. They may be deposited in the public library, if it is a strong and conveniently situated institution, and drawn out by application; while the demand for their use can be stimulated by a committee of volunteers drawn from the original child-welfare exhibit or from the organization now in charge of its affairs. Even if exhibits are taken back by the organization which prepared them they should be catalogued at some central place.

The immediate conscious purpose of the child-welfare exhibit is, after all, not to legislate, nor to combine, nor to convert, but to exhibit, and by exhibiting to educate. It is the answer to a great popular demand for easier and quicker ways of learning.

"We do this for the baby since we went to the coliseum," was a constantly repeated phrase in the round of nurses' visits after the Chicago Child-Welfare Exhibit. "Since the exhibit social workers know each other by their first names," said a Kentucky woman. "Since the exhibit people understand what our board is trying to accomplish," said a prominent city official. "After the exhibit the support given to our society was doubled almost immediately," said a New England worker. "Since the exhibit social work has a new standing in the community," said a prominent citizen of a western city.

Through these subtle changes of attitude and conviction, of individual and community relations, the child-welfare exhibit works out its true purpose of popular education.

APPENDIX I.

CHILD-WELFARE EXHIBITS OWNED BY STATE DEPARTMENTS, JANUARY 1, 1915.

California, State Board of Health, Sacramento.	General health car.
Colorado, State Board of Health, Denver.	Lantern slides.
Florida, State Board of Health, Jacksonville.	Two general health exhibits, including 60 square feet of wall displays referring to children. Motion pictures and lantern slides on general sanitation. Literature and lectures supplied.
Georgia, State Board of Health, Atlanta.	General health exhibit and illustrated lectures.
Illinois, State Board of Health, Springfield.	Extensive general health exhibit of mechanical and still models, electrical devices, and hand-colored cartoons, requiring three booths 10 by 10 by 8 feet for the part relating especially to children. Many models on infant mortality, flies, sanitation, etc. Motion pictures on need of birth registration, etc. Slides, literature, and lecturers sent.
Indiana, Purdue University, La- fayette.	Models of infant clothing and pictures dealing with infant feeding used in lectures on the hygiene of infancy before women's clubs, mothers' club meetings, farmers' institutes, etc.
Indiana, State Board of Health, Indianapolis.	Extensive general health exhibit of 600 square feet wall space, about one-fifth of which is devoted to child hygiene. Models on sanitation. Six motion-picture films, 800 slides. Literature and lecturers furnished.
Indiana University, Bloomington.	Traveling exhibit of eight screens suggesting what any community can do for itself and for its children.
Iowa, State Department of Health and Medical Examiners, Des Moines.	Extensive general health exhibit, including 100 square feet of wall space for exhibits relating to children. Models on patent medicines, baby saving, sanitation, etc.
Iowa, State University, Iowa City.	One hundred wall charts, 3 by 5 feet each. A physician supplied for organizing and conducting baby health contests and conferences.
Kansas, State Board of Health, Topeka.	General health exhibit, including 500 square feet of wall charts on care of babies. Motion pictures and slides. Literature and lecturers.

- Kansas, State University, Lawrence. Exhibits showing surveys of Lawrence and Bellville, 200 square feet of wall space. Seven motion-picture films, 2,000 slides. Literature and lecturers.
- Kentucky, State Board of Health, Frankfort. General health traveling exhibit.
- Louisiana, State Board of Health, New Orleans. Education hygiene exhibit cars and small parish-fair exhibit. One-third to one-fourth on children. Eleven electrical devices, 20 models. Fourteen motion-picture films, 500 slides. Literature and four lecturers continuously (one for negroes).
- Maine, State Board of Health, Augusta. Exhibits on child welfare, school hygiene, rural hygiene, tuberculosis (about 600 square feet wall space). Framed cards and cards on burlap strips. Table exhibits, slides. Large variety of literature, lecturers.
- Michigan, State Board of Health, Lansing. General health exhibit, including charts and models on child hygiene and sanitation. Slides and lecturers.
- New Jersey, State Board of Health, Trenton. General health exhibit and motion-picture machine. Lecturer.
- New York, State Department of Health, Albany. Three exhibits on rural sanitation and three on child welfare. Each child-welfare exhibit requires 70 linear feet of wall space and 15 by 21 foot booth for infant-welfare station. Models, motion pictures, slides. Pamphlets and lecturers. Exhibit manager, nurse, and mechanic with each exhibit.
- North Carolina, State Board of Health, Raleigh. Exhibit on general health, including child hygiene. Models. Slides and lecturers. Parcel-post exhibits for small communities.
- Ohio, State Board of Health, Columbus. Public-health exhibit on infant mortality, blindness, school hygiene, dental hygiene, communicable diseases, occupational diseases, tuberculosis. Requires room 30 by 80 by 14 feet. Models and electrical devices. Ten films, 1,500 slides. Leaflets and lecturer.
- Pennsylvania, State Department of Health, Harrisburg. Exhibit on infant welfare, 1,200 square feet of wall space. Special help for communities preparing their own exhibits, blue prints, etc.¹
- South Carolina, Winthrop Normal and Industrial College, Rock-hill. Extension work includes formation of home-keepers' clubs for girls and of mothers' circles for the study of the child. Baby contests and conferences arranged. Demonstrations of sleeping quarters for the child. Equipment for milk modification. Feeding charts. Literature distributed.
- Tennessee, State Board of Health, Lebanon. Charts, motion pictures, literature, and lectures on typhoid, tuberculosis, hookworm.
- Texas, State Board of Health, Austin. Car on general health and infant hygiene.

¹ This department has a large exhibit in the Panama-Pacific Exposition, which should be available after Jan. 1, 1916.

- Texas, State University, Austin. Forty panels on better babies, 10 on child labor.
Models and electrical devices.
Motion-picture machine, 500 slides.
Thirty bulletins.
- Utah, State Board of Health, Salt Lake City. Slides, literature, and lectures.
- Vermont, State Board of Health, Burlington. Motion pictures on milk, water, vital statistics, tuberculosis. Slides and lectures.
A motion-picture machine with electrical motor generator for use in rural districts where electricity is not available.
- Virginia, State Board of Health, Richmond. Charts on tuberculosis, hookworm, typhoid, 300 square feet wall space. About one-half refers to children.
Kinetoscope, with films on fly, mosquito, care of baby, etc. 250 slides.
Literature and lecturers.
- Washington, State Board of Health, Seattle. A few wall charts and pamphlets on the care of the baby.
- Wisconsin, State University, Madison. One hundred and twenty-five charts on health. Section devoted to children requires 75 square feet wall space.
Models and electrical devices.
Five films and 1,000 slides.
Literature and lecturers.

All technical terms are avoided in order to bring the suggestions within range of the understanding of a mother of average intelligence.

1. (Summary of above record.) This child has thin, pinched nostrils and contracted chest, due, probably, to presence of adenoids, which make it impossible for him to breathe properly. He is over height but under weight, and is not as well developed as a child of his age ought to be, because he can not get into his lungs enough oxygen to make good blood.

This may retard his mental development, making it hard for him to keep up with his school work.

His adenoids ought to be removed and he be kept out of doors day and night if possible. Give simple, nourishing food as per accompanying dietary.

Don't send him to school this year. Build him up first.

2. This child is a credit to an intelligent mother and shows the advantages of breast feeding. She is well developed, in good proportions, and seems in fine condition.

Keep her so by an out-of-door life, regular habits, simple, wholesome food. No eating between meals, no late hours nor moving-picture shows, no crowding in school work.

Her teeth need her constant care and the oversight of a dentist. Decaying teeth mean decomposing food and indigestion.

3. This baby is thin and poorly nourished. He shows that he is not getting the right kind of food. Don't waste your time and his strength experimenting. Take him to a good children's specialist and follow his directions.

He is also overclothed. The band is no longer necessary; it is full of wrinkles and very uncomfortable. Pin his shirt to diaper; also his stockings, which should be long enough to cover entire leg. He may need the short sack night and morning, but don't let his body get wet with perspiration, as it makes him susceptible to colds.

Change all clothing at night and air thoroughly. He ought to sleep only in shirt, diaper, and gown (flannelette in winter and muslin in summer). If he can sleep in a protected corner of the porch he will become less susceptible to colds. In that case make sleeping bags by accompanying pattern, only drawing in sleeves with draw string in winter to keep his hands warm.

4. This is a tiny baby and needs breast milk. Try to get your own health in better condition so that your milk will not give out. Drink milk and cocoa instead of tea and coffee, eat only simple, nourishing food, have a nap on the porch every day while the baby is asleep, and make up your mind to nurse him six months anyway. You can if you will.

Four-hour intervals will be better both for your baby and yourself.

Your doctor will help you when he sees that neither of you are in good condition.

5. James is a big, well-built boy, has good color, and seems in fine condition, except for his knees, which are too prominent, and his ankles, which are big and bulging on the inner side. He may have walked before his ankles were strong enough to bear his weight or his food may not have contained enough bone-producing elements.

He needs careful feeding and special care to prevent a permanent malformation of the ankle and a flattened arch of the foot. Would suggest the advice of a good orthopedist in selection of his shoes and to give him any possible preventive care.

6. Abram is suffering from faulty feeding. His bow legs and roughened, flaring ribs show that his bones are not developing well, and his teeth are slow in coming, because he needs a food with more bone-producing material. Cows' milk is more like mother's milk than the manufactured food you are using. He needs a little orange juice every day. Take him to a milk station, and they will help you secure the best possible food for your baby.

7. Baby Blank seems to be a happy, well-nourished baby. She weighs more than the average child of her age, but has rather more fat than muscle. Her abdominal measurement is greater in proportion to her chest and head than is considered normal. This is probably due to distention of the intestines.

Cream of wheat, bread, and potatoes are more starch than she needs. Don't give potato under 14 to 16 months. Try strained oatmeal, cooked slowly for two hours, instead of cream of wheat, for her constipation. Give also pulp of stewed apples, peaches, or prunes every day in addition to the orange juice. A tablespoonful of beef juice squeezed from a bit of lightly broiled round steak is better for a child of her age than so much starchy food.

Teach her habits of regularity in order to overcome her constipation.

APPENDIX 3.

TABLE OF WEIGHTS AND MEASURES.

Used as a standard of comparison for the Children's Health Conference in the exhibit of the Children's Bureau in the Panama-Pacific Exposition. Figures for children of 3 years and under are obtained from the more-detailed anthropometric table published by the Council on Health and Public Instruction of the American Medical Association and are based on measurements of 4,480 babies in 23 States. As this table does not go above 42 months, the figures for the older children are taken from Holt's measurements.

Age.	Weight.		Height.		Head.		Chest.		Abdomen.	
	Male.	Female.	Male.	Female.	Male.	Female.	Male.	Female.	Male.	Female.
Birth.....	7.55	7.16	20.6	20.5	13.9	13.5	13.4	13.0	16.875	16.375
6 months.....	17.875	16.0	26.50	25.875	17.5	17.0	17.375	16.75	17.125	16.625
1 year.....	21.25	20.875	29.375	28.75	18.5	18.25	18.375	18.125	17.875	17.875
2 years.....	27.5	26.625	33.5	33.5	19.375	19.0	19.624	19.5	18.75	19.0
3 years.....	32.125	30.75	37.125	36.375	20.0	19.5	20.5	20.0	19.875	19.75
4 years.....	36.0	35.0	38.0	38.0	19.7	19.5	20.7	20.7
5 years.....	41.2	39.8	41.7	41.4	20.5	20.2	21.5	21.0
6 years.....	45.1	43.8	44.1	43.6	23.2	22.8
7 years.....	49.5	48.0	46.2	45.9	23.7	23.3
8 years.....	54.5	52.9	48.2	48.0	24.4	23.8
9 years.....	60.0	57.5	50.1	49.6	25.1	24.5
10 years.....	66.6	64.1	52.2	51.8	21.0	20.7	25.8	24.7
11 years.....	72.4	70.3	54.0	53.8	26.4	25.8
12 years.....	79.8	81.4	55.8	57.1	27.0	26.8
13 years.....	79.8	81.4	55.8	57.1	27.7	28.0
14 years.....	88.3	91.2	58.2	58.7	28.8	29.2
15 years.....	99.3	100.3	61.0	60.3	30.0	30.3
16 years.....	110.8	108.4	63.0	61.4	21.8	21.5	31.2	30.8
16 years.....	123.7	113.0	65.6	61.7

APPENDIX 4.

ANNOUNCEMENT AND ENTRY FORM OF THE SEATTLE JUNIOR EXPOSITION.

"Character is determined by the use of leisure time."

CHILD-WELFARE EXHIBIT,

May 22 to 30, 1914.

JUNIOR EXPOSITION,

Saturday, May 23, 10 a. m. to 10 p. m.

CENTRAL COURT OF THE ARMORY.

An exposition of the work of the boys and girls of Seattle, to show something of their skill, perseverance, and ingenuity, and how they use their leisure time.

PLAN.

Open to all boys and girls of Seattle under 16 years of age, residents of the city. Exhibitors will be classified according to age: Entry A, under 13 years of age; Entry B, under 16 years of age.

This exposition, for one day, will include anything made by a boy or girl outside of school hours.

EXHIBITS.

All entries must have been made by the exhibitor outside of school hours. In the department of pets the entries must be the property of the exhibitor.

AWARDS.

All entries will be judged by competent judges, who will award—first prize, blue ribbon; second prize, red ribbon—to all those deemed worthy.

No entries received after May 18.

Bring or send your article to the armory at 9 a. m. Saturday, May 23, 1914.

Labels or cards of identification will be supplied to secure uniformity.

DEPARTMENTS.

(All work made by the exhibitors.)

Gardening.—Exhibits of fruit, flowers, and vegetables raised by the exhibitor.

Woodwork.—Furniture, tables, chairs, boxes, cabinets, shelves, etc. Wood turning, bowls, vases, cup frames, etc. Patterns for castings.

Toys.—Toys of all kinds, of any material; boats, windmills, automobiles, engines, aeroplanes, games, etc.

Electrical and mechanical.—All kinds of electrical or mechanical apparatus. Current can be supplied if necessary.

Printing.—Samples of amateur work. Billheads, cards, etc.

Arts and crafts.—Entries must show design and hand skill. Baskets, books, booklets, block printing, stenciling, leather work, weaving, etc.

Domestic science.—Bread, canned and preserved fruit and vegetables; menus, etc.; household appliances.

Domestic art.—Coats; woolen, silk, and cotton waists or skirts; one-piece dresses, gowns, aprons, bags, collars, cushions, scarfs, slippers, caps, etc.; hand-woven mats and rugs; 9 to 12 inch doll, dressed in hand-made garments; patching, darning, etc.

Millinery.—Handmade buckram or wire frames, infants' and children's bonnets, girls' hats, 12 to 16 years; bows, flowers, etc.

Pets.—All kinds of pets owned by the exhibitor. Dogs, cats, poultry, rabbits, squirrels, birds, fish, turtles, etc.

Each exhibitor must provide for the care of his exhibit.

Junior Exposition Committee of the Child-Welfare Exhibit: Ben W. Johnson (chairman), Harry L. Deits (director), Anna E. Grady, Low S. McKean, Susan E. Campbell, Lila M. Delano, William P. Casey, Harry B. Cunningham, Laurance H. Lemmel, Samuel C. Olson, Ed J. Turner.

ENTRY FORMS.

The attached form blank should be filled out as directed by every boy or girl who expects to participate in this exhibit.

(Cut here.)

ENTRY FORM.

Name ----- Age -----

Address: No. ----- Street -----

School, club, or where employed -----

Article ----- Department -----

N. B.—Make but one entry on this form. As soon as filled out return it to the principal of your school or send it to Mr. Johnson, Room 338, Central Building. Phone Main 2644.

APPENDIX 5.

THE EXHIBIT OF THE CHILDREN'S BUREAU AT THE PANAMA-PACIFIC EXPOSITION.

In preparing its exhibit for the Panama-Pacific Exposition the Children's Bureau decided to center its attention on a "Children's Health Conference"; to group around this charts, models, and living demonstrations on infant welfare, home play, and child labor; and to maintain at the same time an information bureau to direct inquirers to other exhibits on the fair grounds dealing with phases of child welfare. To the charts and models prepared in Washington, and illustrating the work of the bureau, were added carefully chosen exhibits loaned by local organizations. Local organizations also furnished living exhibits and demonstrations and cooperated with the bureau in conducting both the conference and the exhibit. Different hospitals assigned nurses for regular hours each day to assist in the examination room. Different women's clubs acted as hostesses and explainers in the exhibit for periods of two weeks each.

A list of the exhibits will serve to indicate the extent of this cooperation and may prove suggestive to communities planning to hold child-welfare exhibits. All permanent exhibits not otherwise designated are the property of the bureau, and will be loaned for use on application by local exhibitors after December 4, 1915. Duplicates of the lantern slides and photographic copies of the panels (size 20 by 40 inches) are available immediately.

CATALOGUE OF THE EXHIBIT.

LIVING DEMONSTRATIONS.

Children's health conference.—Free medical examination of children under 15 years, 10 to 12, 2 to 5, except Saturdays, Sundays, and Wednesday afternoons.

Baby clinic.—Wednesdays 2 to 5, demonstration clinic showing baby hygiene work as carried on in San Francisco under the Certified Milk and Baby Hygiene Committee of the Association of Collegiate Alumnae, and the Associated Charities.

Food for children.—Mondays, Wednesdays, and Fridays, 2 to 5 p. m.; Baby feeding and preparation of milk, in charge Certified Milk and Baby Hygiene Committee, Association of Collegiate Alumnae.

Tuesdays, Thursdays, and Saturdays: Preparing food for young children, in charge Department of Nutrition, University of California.

Home play.—Demonstrations of home toy making, painting, basket making, and use of back-yard apparatus, in charge recreation authorities of San Francisco and Oakland and Columbia Park Boys' Club.

PERMANENT EXHIBIT.

Our thirty million children.—Large moving panorama showing the number of children dying before the age of 5 years and the number in school or at work at various ages.

Infant welfare.—Fifteen wall frames, 3 by 6 feet, dealing with birth registration; prenatal care; the relation of infant mortality to poverty, ignorance, and bad surroundings; the importance of breast feeding and rules for nursing the baby; artificial feeding and pure milk; the working mother; and mothers' pensions. (Smaller reproductions of 12 of these panels, 20 by 40 inches, are available for loan to local exhibits.)

Village of 100 homes, a model loaned by the North Carolina Board of Health, illustrating by flashing and fading lights the number of babies dying before the end of the first day, the first week, the first month, the first year, and the second year.

Fifty-two slides (shown by an automatic stereopticon) on infant care, including prenatal care, breast feeding, artificial feeding, the baby in the home, summer and winter care.

Red star, fading every 10 seconds, and bearing the inscription, "Every time this star fades, somewhere in Europe or the United States a baby dies; one every 10 seconds, 6 every minute, 360 every hour; half these deaths are preventable."

Glass case, containing soothing sirups and patent medicines obtained from the Department of Agriculture, Bureau of Chemistry, warning parents against the use of such remedies and showing the contents of each specimen.

Small booth on the baby in the home, showing clothing for the baby, a baby's bed properly made and protected from drafts, a basket substitute for a crib, proper utensils for a baby's bath, and a play pen with sanitary toys. Occasional demonstrations are given in this space by the nurse.

A glass case containing a food exhibit prepared by the department of nutrition, University of California, showing the right kinds of food for a young child, the method of preparing those foods for different ages, and the relative value of various foods for building bone, muscle, and flesh, for supplying heat and energy, or for enriching the blood with iron.

A metal sphere showing the proportion of baby deaths in the United States due to various causes.

A metal cone showing how cities in the United States spend their money.

Model of a baby's stomach at birth.

Models of a typical case of adenoids.

Models of normal stools of small baby and stools showing diarrhea. (Used only in the conference room with mothers.)

Models made by the Pasadena High-School girls' class in sanitation, illustrating an effective way of giving a class a knowledge of hygiene. One of these models traces the course of a typhoid epidemic, showing that it is carried by water pollution; the other shows a good and a bad dairy.

Home play.—Three wall frames dealing with the requirements of a comprehensive plan of public recreation, the need of home play for small children, and the proper equipment in house and yard.

Home play yard, loan exhibit from the San Francisco public schools, showing ladders, slide, sand box, and balance beam. (See illustration No. 2.)

Home playroom, containing toys made by children from simple materials. Used as demonstration room.

Children's interests. A collection of articles made by children and secured through the San Francisco schools, the recreation authorities of San Francisco and Oakland, and the Columbia Park Boys' Club.

A revolving wing frame, showing the playgrounds of Oakland.

A scrapbook showing some recent ideas in recreation, including the municipal camp in Los Angeles, the Amenia field day, the play school of the University of California, the Public Schools Athletic League of New York City, and the playground equipment and facilities of Chicago.

Child labor.—Five wall frames containing statistics from the United States census on the number of children gainfully employed and their distribution by age, sex, and geographical division, industry, and occupation.

A map model showing by age and sex groups the proportion of working children in different sections of the country.

Twelve transparencies containing photographs of the typical occupations of children in the United States.

Information bureau.—A set of the publications of the Childrens' Bureau.

A small collection of recent pamphlets published by national societies doing work for children.

Scrapbooks on State child-welfare exhibits, local child-welfare exhibits, traveling child-welfare exhibits.

Information concerning exhibits in the exposition dealing with children.



NO. 1.—CHILDREN'S HEALTH CONFERENCE. DOCTOR, NURSE, PARENT, AND CHILD ARE SEPARATED FROM THE GENERAL PUBLIC BY A GLASS WALL THROUGH WHICH THE EXAMINATION CAN BE SEEN.



NO. 2.—HOME-PLAY EXHIBIT.

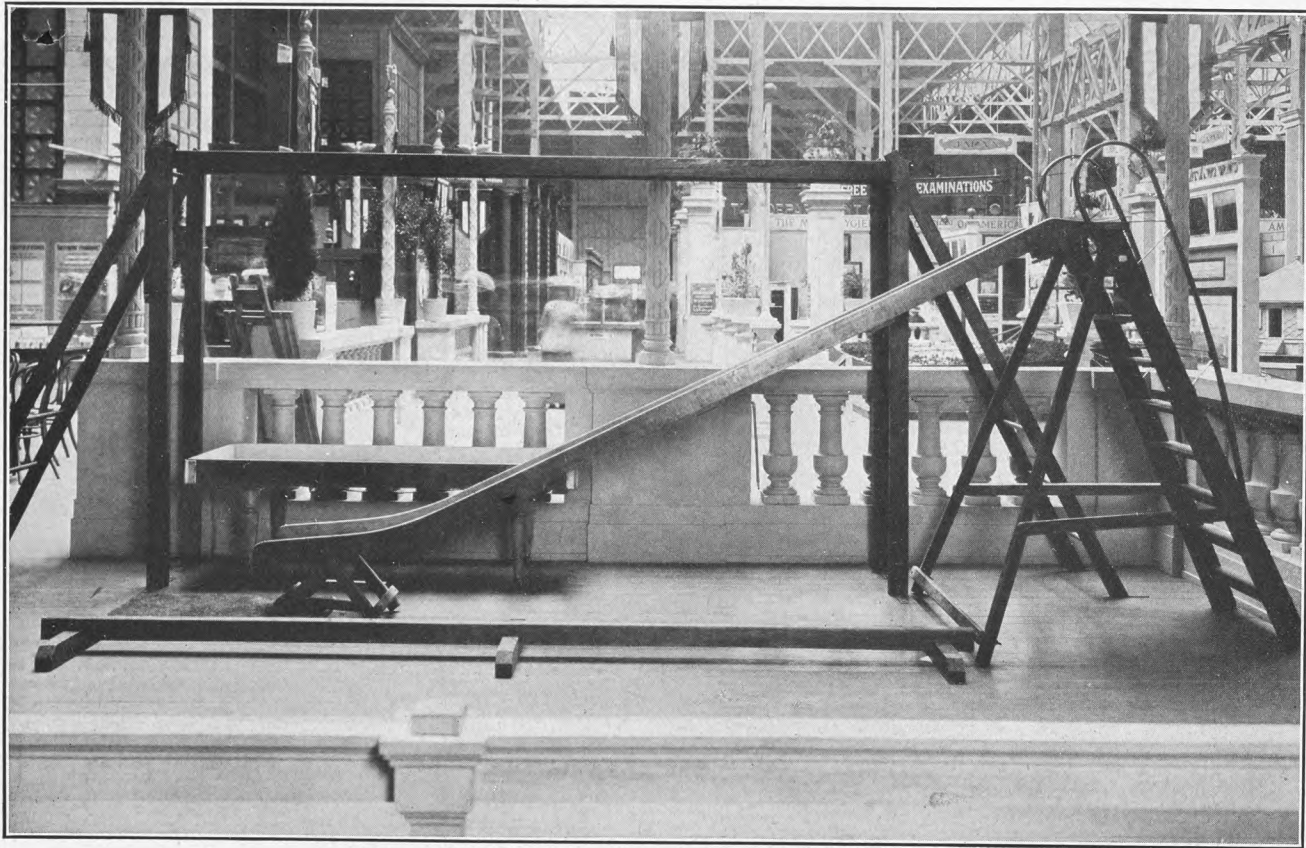

NO. 3.—BALANCE BEAM AND SLIDE IN HOME-PLAY EXHIBIT.

BABY'S FOES

CAPTAINS OF THE HOSTS OF DEATH
ARE
POVERTY
IGNORANCE
BAD SURROUNDINGS.



THOUSANDS AND THOUSANDS OF BABIES
ARE KILLED BY THESE FOES

OTHERS WHO SURVIVE STRUGGLE THROUGH
LIFE BEARING SCARS MADE BY THEM.

NO. 4.—WALL PANEL FROM THE EXHIBIT OF THE CHILDREN'S BUREAU,
SHOWING THE USE OF CARTOONS.

WHAT MOTHER'S MILK DID FOR THIS BABY

THIS BABY WAS ARTIFICIALLY FED AND HAD DIARRHOEA.

SEPT.
19.
1912.



AGE
3
MONTHS.
WEIGHT
4 LB.
3 OZ.

THE DOCTOR SAID:

"ONLY A NURSING MOTHER CAN SAVE THIS BABY"
A CHILDREN'S AID SOCIETY FOUND
THE NURSING MOTHER.

THE
SAME
BABY



JAN. 30,
1913.
WEIGHT,
12 LBS.

MOTHER'S MILK

IS EASY TO DIGEST.
PROTECTS AGAINST
SUMMER DIARRHOEA
AND
OTHER DISEASES.
BUILDS BONE AND FLESH.

NO. 5.—WALL PANEL FROM THE EXHIBIT OF THE CHILDREN'S BUREAU,
SHOWING AN ARRANGEMENT OF PHOTOGRAPHS AND STATEMENTS
PASTED ON A LARGER BACKGROUND WHICH FORMS THE UNIT OF
CONSTRUCTION.

COLDS & PNEUMONIA

A GROWN PERSON'S COLD
MAY BRING
PNEUMONIA
TO THE BABY

ABOUT $\frac{1}{8}$ OF ALL BABIES DYING UNDER
ONE YEAR OLD, DIE FROM PNEUMONIA AND
BRONCHITIS. U. S. CENSUS, 1912.



PROTECT THE BABY
AGAINST ITS MOTHER'S
COLD.



NEVER KISS THE
BABY ON THE MOUTH.



KEEP THE BABY AWAY FROM CROWDED PLACES

GIVE THE BABY PLENTY OF FRESH AIR

NO. 6.—WALL PANEL FROM THE EXHIBIT OF THE CHILDREN'S BUREAU,
SHOWING A COMBINATION OF PHOTOGRAPHS AND CARTOONS.

ARTIFICIAL FOOD

IF THE DOCTOR SAYS
THE BABY MUST BE ARTIFICIALLY FED
GET HIM TO SHOW YOU HOW



GET BOTTLED MILK

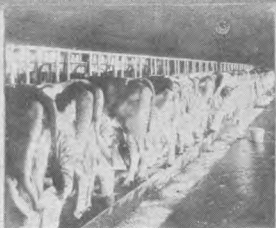

FROM CLEAN COWS

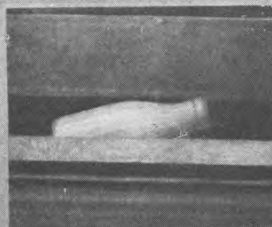

KEEP IT COOL



MIX BY DOCTOR'S ORDERS

CLEAN COW'S MILK
MIXED WITH WATER AND SUGAR AS THE DOCTOR DIRECTS
TO SUIT EACH BABY
IS THE BEST SUBSTITUTE FOR MOTHER'S MILK
FOR NORMAL BABIES.

NO. 7.—WALL PANEL ON INFANT CARE.

NURSING THE BABY

ALMOST
EVERY
MOTHER



CAN
NURSE
HER BABY

NURSE THE BABY IF POSSIBLE FOR 9 MONTHS
EVEN IF SOME ARTIFICIAL FOOD IS NECESSARY IN ADDITION.

EVERY MOUTHFUL OF BREAST MILK
IS IMPORTANT TO THE BABY
ESPECIALLY AVOID WEANING IN THE EARLY MONTHS
OR IN SUMMER

NURSE THE BABY REGULARLY

BY THE CLOCK

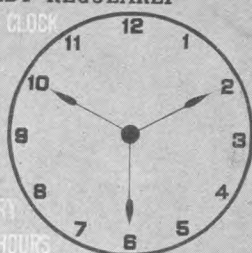
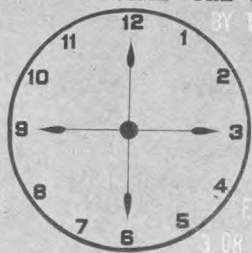

EVERY
3 OR 4 HOURS

(EXCEPT IN THE MIDDLE OF THE NIGHT)

AND FOR 20 MINUTES AT A TIME

DO NOT NURSE BY GUESS WORK,
NOR EVERY TIME HE CRIES.

GIVE THE BABY A DRINK OF
WATER
BETWEEN FEEDINGS, ESPECIALLY IN SUMMER.

NO. 8.—WALL PANEL ON INFANT CARE.

CARE BEFORE BIRTH

BIRTH IS NOT THE BEGINNING OF LIFE
BABIES ARE ALIVE
AND CAN BE SERIOUSLY INJURED
BEFORE BIRTH.



A HEALTHY HAPPY MOTHER **MAKES** A HEALTHY HAPPY BABY.

A MOTHER AWAITING THE BIRTH OF HER BABY
NEEDS {
GOOD FOOD
PLENTY OF REST
FRESH AIR
LIGHT EXERCISE
A CONTENTED MIND

IN THE UNITED STATES (REGISTRATION AREA)
IN 1912

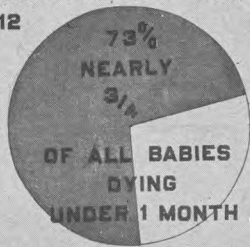
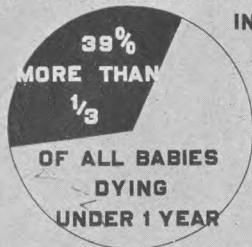

DIED BECAUSE OF CONDITIONS BEFORE BIRTH

INFANT WELFARE WORK
HAS SAVED THOUSANDS OF BABIES.
BUT
OUR DUTY TO THE BABY BEGINS BEFORE BIRTH.

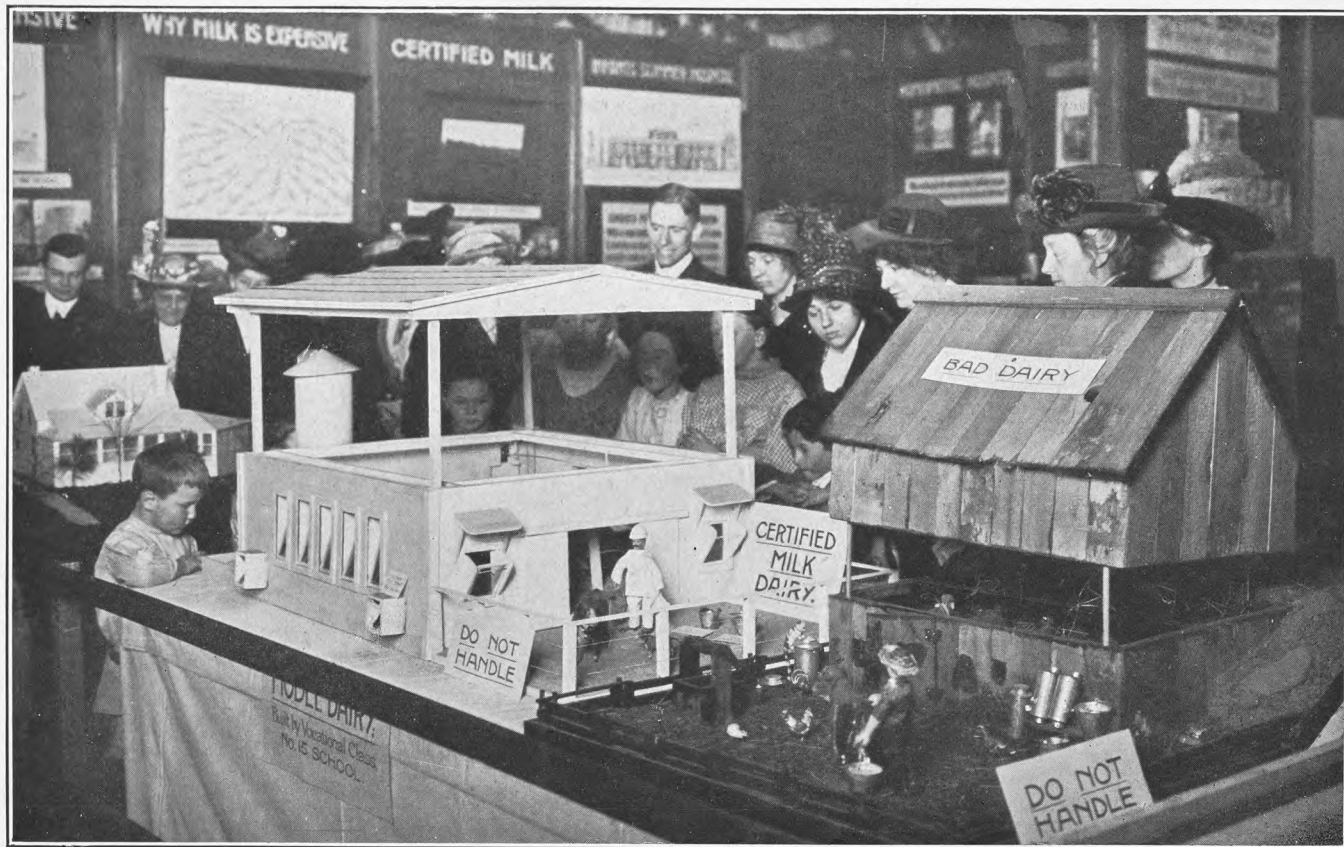

NO. 10.—MODEL MADE FOR A CHILD-WELFARE EXHIBIT BY A VOCATIONAL CLASS IN THE ROCHESTER PUBLIC SCHOOLS.



NO. 11.—DENTAL EXHIBIT COMPRISING PHOTOGRAPHS, STATEMENTS, LANTERN LECTURE, DENTAL EQUIPMENT, MODELS OF TEETH, AND A DEMONSTRATION OF DENTAL EXAMINATION, ALL IN ONE 8 BY 12 SPACE, MADE BY THE ROCHESTER DENTAL SOCIETY.



NO. 13.—A GOOD EXHIBIT FOR A LIBRARY IN A COMMUNITY CHILD-WELFARE EXHIBITION IS A CHILDREN'S ROOM IN OPERATION.

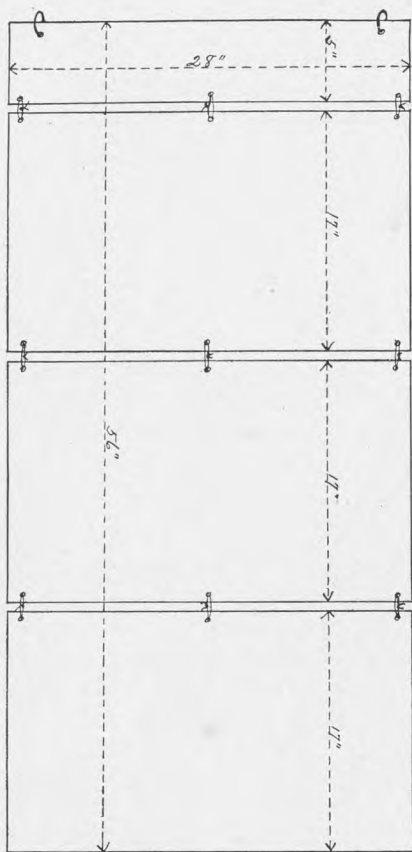

NO. 14.—DIAGRAM OF WALL PANEL
COMPOSED OF CARDS.

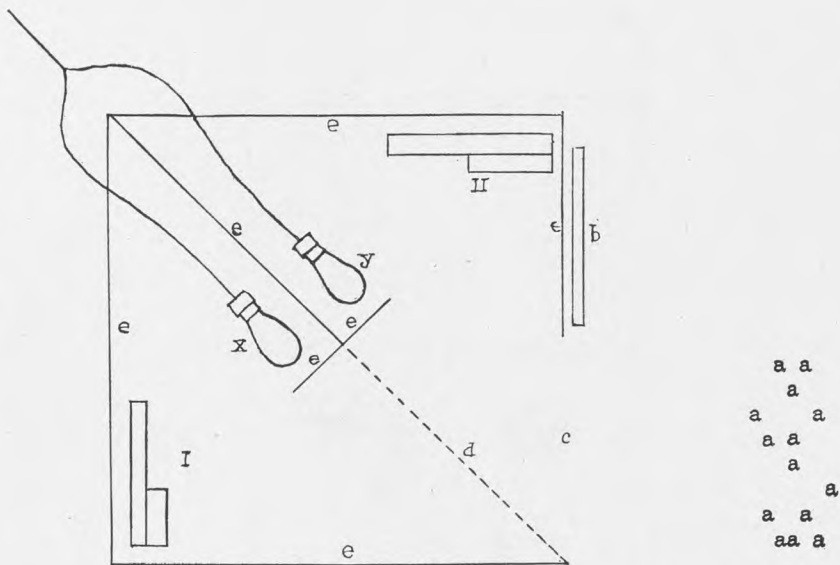

NO. 15.—CROSS SECTION OF AN "ILLUSION." (SIDE VIEW WITH DOOR REMOVED.)

- a. Position of spectator, kept at distance by railing or screen with peephole.
- b. Descriptive sign on front.
- c. Opening through which model is seen.
- d. Glass.
- e. Inside walls, finished in dull black paper.
- x and y. Lights attached to flasher.
- I and II. First and second view of model.

When light x is on, model I is illuminated and is seen through glass d; when light y is on and light x is off, glass d becomes a mirror because of the dark box behind it, and reflects model II.

